



aerospace
climate control
electromechanical
filtration
fluid & gas handling
hydraulics
pneumatics
process control
sealing & shielding



PCL4 Remote Control

Hydraulic Proportional Remote Control Valve



ENGINEERING YOUR SUCCESS.

Catalogue layout

This catalogue has been designed to give an overview of the PCL4 series of valves and to make it easy for you to study and choose from the different valve functions available, so that we may customize your valve in accordance with your wishes. General information and technical data is given first, followed by descriptions of the various options that can be specified and, finally, by dimensional drawings for the respective valves.

Each function is given as a subheading, e.g. **Levers**, followed by a brief description. This is followed by a series of alphanumeric codes, e.g. **H1, H2, E4**, together with a brief description of what each code represents.

How to order your valve

The next step is to complete our so-called “Customer Specification Form”, which enables detailed specification of the optional functions and port-specific control-pressure characteristics you wish to be incorporated into your valve. However, if you require only a simple, basic valve, in which all control-pressure ports have the same configuration, you can specify your valve by determining an ordering code in accordance with the information given on page 5. It is simply a matter of entering the codes for the desired options into the boxes in the ordering code, as shown in the example.

For assistance in configuring your valve, completing the Customer Specification Form or determining the ordering code, please do not hesitate to contact your nearest Parker representative.

The information in your Customer Specification Form will be entered into our computerized valve specification program, which generates a unique ID number that will be stamped into the data plate on your valve. (If you order your valve by means of an ordering code, the code will be stamped into the data plate on your valve.) Your valve specifications will then be stored on our database to facilitate accurate identification of the product in the event of re-ordering or service-related questions.

Early consultation with Parker saves time and money

Our experienced applications engineers have in-depth knowledge of different hydraulic systems and the ways in which they work. They are at your disposal to offer expert advice on the desired combination of functions, control characteristics and economic demands.

By consulting Parker early in the project planning stage, you are assured of a comprehensive hydraulic system that gives your machine the best possible operating and control performance.

Conversion factors

1 kg	= 2.2046 lb
1 N	= 0.22481 lbf
1 bar	= 14.504 psi
1 l	= 0.21997 UK gallon
1 l	= 0.26417 US gallon
1 cm ³	= 0.061024 in ³
1 m	= 3.2808 feet
1 mm	= 0.03937 in
9/5 °C + 32	= °F

Subject to alteration without prior notice. The diagrams in the catalogue show typical curves only. While the contents of the catalogue are updated continuously, the validity of the information given should always be confirmed. Technical information in the catalogue is applicable at an oil viscosity of 30 mm²/s and temperature of 50 °C. For more detailed information, please contact Parker.

Contents	Page 5-2-
Catalogue Information	2
General Information	4
Ordering Code	5
Technical Data	6
Lever forces	7
Electrical data	7
Connections	7
Weight	7
Valve type	8
Control pressure ports	8
Connections	8
Location of connections	8
Control pressure	8
Mounting plate	9
Extra centring springs	9
Lever E1	9
Levers E2, E3, E4	9
Activating devices	10
Lever N2T	10
Lever N4T	10
Lever detents for PCL402	11
Friction brake for PCL402	11
Shuttle valve for signal on activation of valve	11
PCL401 levers	12
Dimensional Drawings	12-17

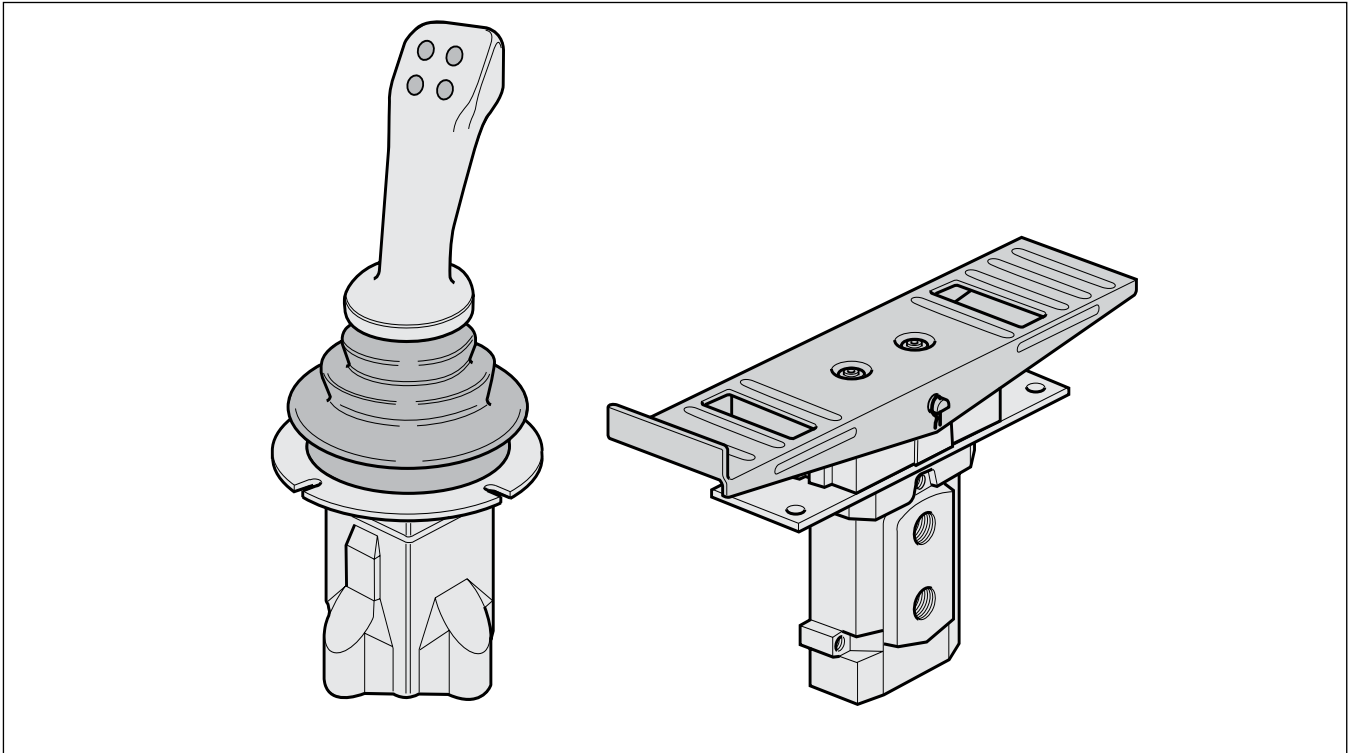

The PCL4 is a stackable hydraulic control-pressure valve intended for the proportional, hydraulic remote control of directional valves, pumps with variable displacement, positioning cylinders, etc. It can be obtained with a co-ordinate lever (joystick), linear lever or foot pedal as the activating device.

Freedom in machine design

Good machine design is heavily dependent on the availability of versatile components and systems that can be combined in different ways to give optimum operating and control characteristics. Parker control systems give you the freedom to design your machines the way you want them, since they enable components such as directional valves and other control devices to be located ideally on the machine. This also gives advantages in production, since it greatly facilitates the building of machine sub-assemblies at different sites prior to collation for final assembly.

Parker supplies a wide range of pneumatic, hydraulic and electric control devices that enable optimum ergonomic design of the machine-control station. (Please see separate brochures for information on our hydraulic and electric remote-control systems.)

Safety

The robust and simple construction of the PCL4 remote control valve makes it very

reliable and greatly facilitates training and servicing. This, together with consistently predictable control properties, gives a high level of operational safety for many years.

Design

The valve is made up of sections, each of which contains two 3-way pressure reducing valves (one per signal port). Up to 6 sections can be stacked into one and the same valve to give a total of 12 signal ports. Valves with four signal ports can be equipped with a coordinate lever (joystick). The cast-iron valve housing and reducer-valve spools of hardened, precision-ground steel ensure a long service life with minimal internal leakage. Special low-friction seals give effective protection against external leakage.

The PCL4 is designed to give minimal hysteresis and very good long-term control characteristics.

Levers are of corrosion-resistant steel and can be fitted with plastic handles, balls or window knobs. Pedals can be of corrosion-resistant, pressed steel plate, aluminium or rubber-coated steel.

Essential characteristics

- Small dimensions enable simple, compact installation.
- Robust, simple design gives great reliability and easy servicing.
- Low, well-adapted lever forces and short lever strokes give good operating comfort.

- Lever forces can be specified per control-pressure port to give function-specific actuation resistance.
- Low hysteresis gives consistent machine-function response to valve actuation.
- Good metering properties enable gentle, proportional control.
- Very wide range of control-pressure characteristics enables control of machine functions to be application-optimized.
- Wide range of control devices and accessories gives great flexibility in system design.
- Valve can be installed in arm rests of operator's seat and fitted with site-suited lever to give very ergonomic control station.
- Quality materials and great precision in manufacturing, assembly and testing assure a quality product with low internal leakage and long service life.
- Total compatibility with Parker directional valves gives predictable and harmonious system characteristics.

PCL4	□	—	□	—	□	—	□	—	□	—	□	—	□
	Valve type		Control pressure ports		Thread connection		Pump and tank connection		Mounting plate		Lever unit	Lever type	Characteristics

Code	Valve type
01	For coordinate lever
02	For linear lever(s) or pedal

Code	Lever unit
H1	Coordinate lever
H3	Straight linear lever
HF	Bent linear lever for increased spacing in case of several levers
E1	Linear or coordinate lever 2-position thumb switch
E2	Linear or coordinate lever 3-position toggle switch
E3	Linear or coordinate lever 3-position toggle switch 1 detent position
E4	Linear or coordinate lever 3-position toggle switch 2 detent positions
N0	Coordinate lever without thumb switch
N2	Coordinate lever with 2 thumb switches
N2T	Coordinate lever with 3 thumb switches
N4	Coordinate lever with 4 thumb switches
N4T	Coordinate lever with 5 thumb switches
F	Pedal, pressed steel
A36	Pedal, cast aluminium
A95	Pedal, rubber coated steel plate

Code	Lever type
S	Straight*
L	Bent to the left*
R	Bent to the right*
B	Ball**
W	Window**

* Type N levers only
** Type H levers only

Code	Mounting plate
M1	Mounting plate for PCL401
M2	Mounting plate for PCL402 with four control-pressure ports
M3	Mounting plate for PCL402
M4	Mounting plate for PCL402 with two control-pressure ports
M5	Mounting plate for PCL402
M6	Mounting plate for PCL402
M9G	Mounting plate for PCL402 for Gresen replacement
M10C	Mounting plate for PCL402 for Commercial replacement
A102	Mounting plate for PCL401, rectangular bellows (for PCL401 with N-type levers only)

Code	Thread connections
G	G1/4
U	9/16-18 UNF-2B
M	M14x1.5

Code	Connection
S	Pump and tank connections on side of valve
B	Pump and tank connections on underside of valve

Number of control-pressure ports	
2	
4	
6	
8	
10	
12	

Code	Characteristic																																																																											
	<table border="1" style="width: 100%; border-collapse: collapse;"> <thead> <tr> <th>No</th> <th>Breakaway pressure</th> <th>Final pressure</th> <th>Broken</th> <th>Overtr. stroke</th> </tr> </thead> <tbody> <tr><td>11.0</td><td>11.1</td><td></td><td></td><td></td></tr> <tr><td>22.0</td><td>5.4</td><td></td><td></td><td></td></tr> <tr><td>32.0</td><td>10.5</td><td></td><td></td><td></td></tr> <tr><td>45.0</td><td>15.6</td><td></td><td></td><td></td></tr> <tr><td>55.0</td><td>17.7</td><td></td><td></td><td></td></tr> <tr><td>65.0</td><td>20.9</td><td></td><td></td><td></td></tr> <tr><td>75.0</td><td>24.9</td><td></td><td></td><td></td></tr> <tr><td>85.5</td><td>15.6</td><td></td><td></td><td></td></tr> <tr><td>95.6</td><td>21.5</td><td></td><td></td><td></td></tr> <tr><td>10</td><td>6.0</td><td>27.2</td><td></td><td></td></tr> <tr><td>11</td><td>4.0</td><td>22.6</td><td>yes</td><td></td></tr> <tr><td>12</td><td>5.0</td><td>27.0</td><td>yes</td><td></td></tr> <tr><td>13</td><td>6.0</td><td>27.5</td><td>yes</td><td></td></tr> <tr><td>14</td><td>5.0</td><td>16.5</td><td>yes</td><td>yes</td></tr> </tbody> </table>	No	Breakaway pressure	Final pressure	Broken	Overtr. stroke	11.0	11.1				22.0	5.4				32.0	10.5				45.0	15.6				55.0	17.7				65.0	20.9				75.0	24.9				85.5	15.6				95.6	21.5				10	6.0	27.2			11	4.0	22.6	yes		12	5.0	27.0	yes		13	6.0	27.5	yes		14	5.0	16.5	yes	yes
No	Breakaway pressure	Final pressure	Broken	Overtr. stroke																																																																								
11.0	11.1																																																																											
22.0	5.4																																																																											
32.0	10.5																																																																											
45.0	15.6																																																																											
55.0	17.7																																																																											
65.0	20.9																																																																											
75.0	24.9																																																																											
85.5	15.6																																																																											
95.6	21.5																																																																											
10	6.0	27.2																																																																										
11	4.0	22.6	yes																																																																									
12	5.0	27.0	yes																																																																									
13	6.0	27.5	yes																																																																									
14	5.0	16.5	yes	yes																																																																								

See pages 8 - 11 for more information about the different options available.

How to order your valve

The best way to order your valve is to fill in one of our "Customer Specification Forms", in which you can specify all the optional functions you wish to be incorporated into your valve. However, if you need only a simple, basic valve, in which all control-pressure

ports have the same configuration, you may use an ordering code similar to the one shown above. Simply select the desired options from the tables above and enter the appropriate codes into the boxes in the ordering code above.

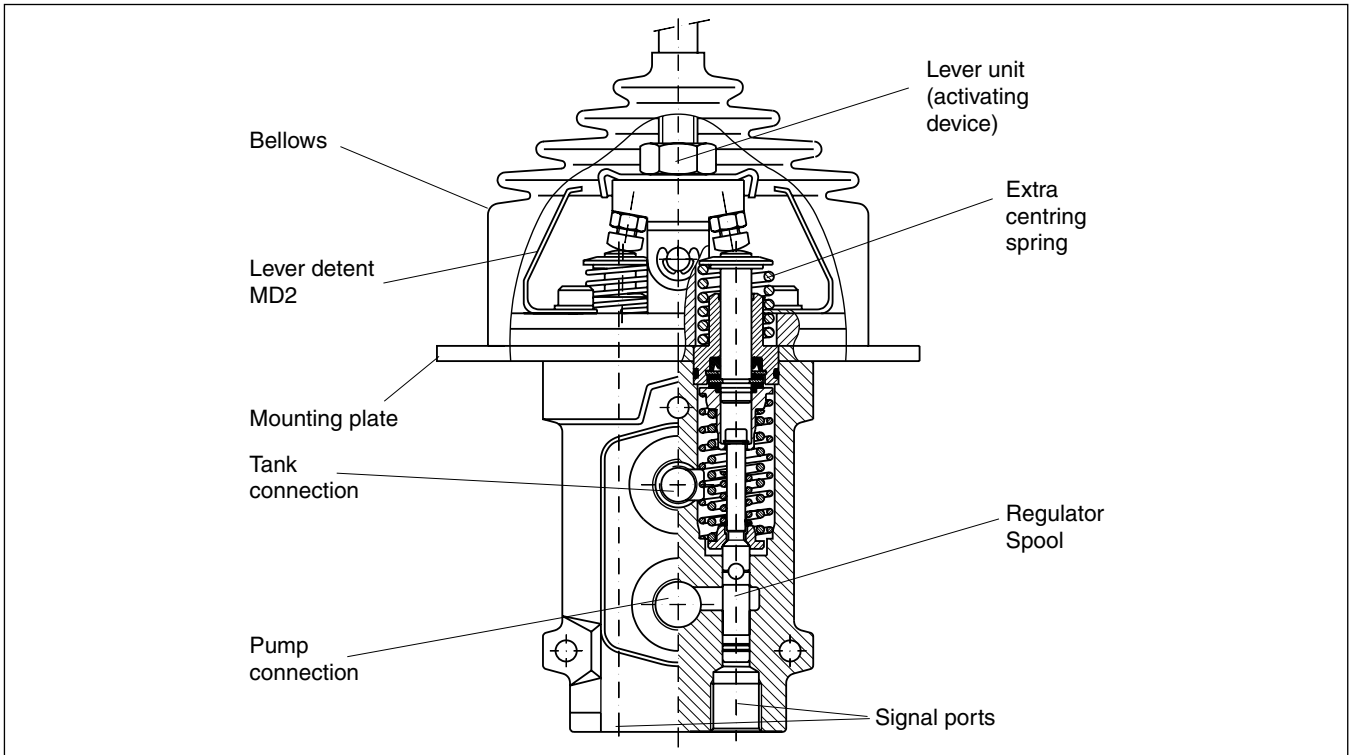

General

The data given is applicable at an oil temperature of 50 °C (122 °F) and viscosity of 30 mm²/s (cSt) using mineral base oil according to DIN 51524.

Pressures

Supply pressure (pump pressure)	max. 100 bar (1450 psi)
Recommended supply pressure	15 bar (218 psi) higher than max. control pressure
Control pressure	max. 75 bar 1090 psi)
Breakaway pressure	min. 1 bar, (14,5 psi) max. 16 bar (232 psi)
Return-line pressure	max. 3 bar (44 psi)

Flow rate

Control flow	max. 15 l/min (4 USgpm)
--------------	-------------------------

Hysteresis

Hysteresis	max. 0.5 bar (7,3 psi)
------------	------------------------

Hydraulic fluids

Best performance is obtained using mineral-base oil of high quality and cleanness in the hydraulic system.
HLP hydraulic fluids (DIN 51524), automatic-gearbox oil type A and API CD engine oils can be used.

Viscosity range	10-380 mm ² /s (cSt)
-----------------	---------------------------------

Performance efficiency will be reduced if outside the ideal values. These extreme conditions must be evaluated by the user to establish suitability of the products performance.

Filtration

Filtration should be arranged so that the Target Contamination Class 18/16/13 according to ISO 4406 is not exceeded.

Technical information in this catalogue is applicable at an oil viscosity of 30 mm²/s and temperature of 50 °C using nitrile rubber seals.

Temperature

Min. ambient temperature	-40 °C (-40 °F)
Max. ambient temperature	+60 °C (140 °F)
Min. oil temperature	-20 °C (-4 °F)
Max. oil temperature	+70 °C (166 °F)
Temperature change	max. 100 °C/s. max. 212 °F/s

Product operating limits are broadly within the above range, but satisfactory operation within the specification may not be accomplished. Leakage and response will be affected when used at temperature extremes and it is up to the user to determine acceptability at these levels.

Leakage

From pump connection to tank connection with the spool in neutral position and a supply pressure of 40 bar (580 psi)	max. 20 cm ³ /min (1.22 in ³)per control-pressure port
--	---



Warning

If the filtration demands are not met, the valve poppets can jam in the open position, with the result that the valve remains actuated. It is not possible to force back jammed poppets mechanically.

Lever forces

All lever forces stated are applicable at a control pressure of 15 bar (valve not fitted with an extra centring spring). Pedal forces are applicable when the C2 centring spring is used (see page 9).

Normal force for linear lever, fully actuated	1.2 Nm
Normal force for coordinate lever (joystick) one function fully actuated	1.8 Nm
two functions fully actuated	2.4 Nm
Normal force for pedal, fully actuated	5.7 Nm

Electrical data

(applies to switch in E- and N-type levers)

The data given below is what is needed to obtain the maximum service life. The values can be exceeded with retained function, but will result in a reduction in service life. In the event of inductive loading, a protective diode must be fitted.

Breaking capacity

DC, resistive loading	2A/24V
DC or AC, inductive loading	1A/24V

Connections

Three different types of connection thread are available:
 G1/4 for flat seal (type Tredo) according to ISO 228/1 (G version)
 9/16-18 UNF-2B (for O-ring) according to SAE J1926/1 (U version)
 M14 x 1.5 (metric ISO thread) for flat seal (M version)

Weight

The weight of the unit varies with its configuration. A few examples are given below.

Valve with linear lever	approx. 1.6 kg/section
Valve with coordinate lever	approx. 3.2 kg
Valve with pedal (F)	approx. 3.0 kg

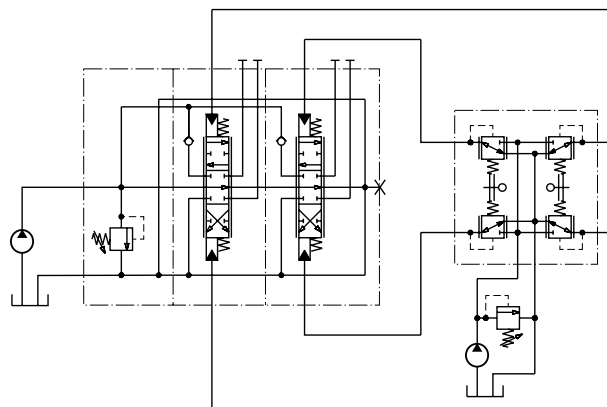

Circuit diagram showing two-section PCL4 with two linear levers controlling one hydraulic directional valve containing two spool sections.

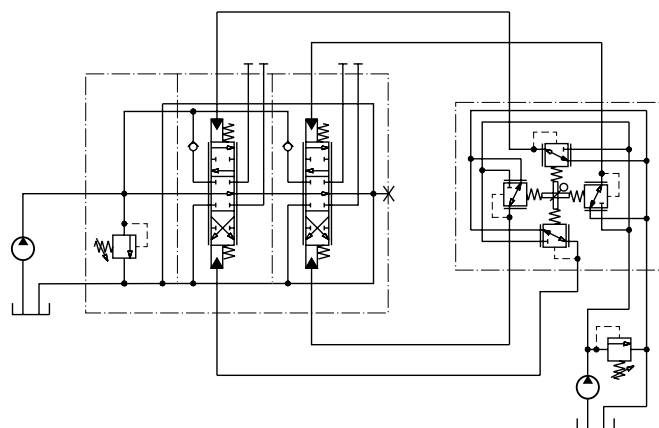

Circuit diagram showing two-section PCL4 with one coordinate lever (joystick) controlling one hydraulic directional valve containing two spool sections.

5

Every valve is customized. The following options are used to configure a valve.

Valve type

PCL401 Valve with coordinate lever (joystick)

PCL402 Valve with linear lever(s) or pedal

Control pressure ports

2-12 4 in PCL401
2, 4, 6, 8, 10 or 12 in PCL402

Connections

- G** Connections with G1/4 thread
- U** Connections with 9/16-18 UNF-2B thread
- M** Connections with M14 x 1.5 thread

Location of connections

All control-pressure ports are located on the underside of the valve. The pump and tank connections can be located on the underside or side of the valve. See dimensional drawings.

- S** Pump and tank connections fitted on the side of the valve.
- B** Pump and tank connections fitted on the underside of the valve.

Control pressure

Control pressure characteristics can be obtained in an almost infinite number of versions. They are classified into four different groups.

- Straight characteristic
- Straight characteristic with overtravel stroke
- Broken characteristic
- Broken characteristic with overtravel stroke

With the straight characteristic, the control pressure changes proportionally with the lever stroke. With the broken characteristic, the control pressure changes proportionally with the lever stroke up to a pre-determined breakpoint, after which the characteristic continues to change proportionally, but with a steeper characteristic. This is useful when there is a big difference between break-out pressure and final pressure and a need to fine-regulate the beginning of the stroke.

With the overtravel stroke, the control pressure becomes equal to the supply pressure. This is recommended primarily for directional valves that have a free flow gallery (CFO). The overtravel stroke serves to ensure full actuation regardless of any return-spring tolerances in the spool actuator of the directional valve.

To calculate a suitable control-pressure characteristic, the following information is needed:

Breakout pressure:

The pressure at which the valve just begins to open. Selectable between 1 and 16 bar.

Final pressure:

Max. control pressure (fully actuated activating device) or, in case of overtravel stroke, the pressure level obtained on reaching the overtravel stroke. Selectable between 5.5 and 75 bar.

Breakpoint:

The lever stroke and pressure at which the broken characteristic changes characteristic.

Overtravel stroke:

The part of the activating-device stroke that constitutes overtravel.

For assistance in calculating the most suitable control-pressure characteristic, please contact your nearest Parker representative.

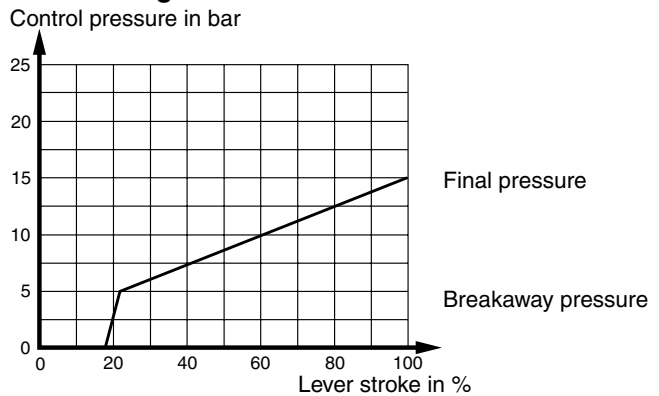

Diagram shows an example of a straight characteristic.

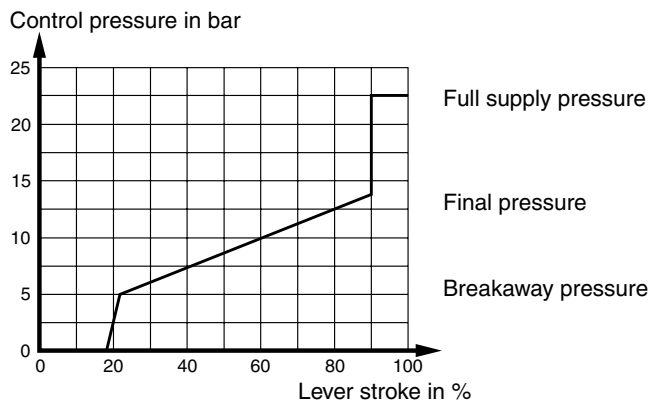

Diagram shows an example of a straight characteristic with overtravel stroke that gives full supply pressure.

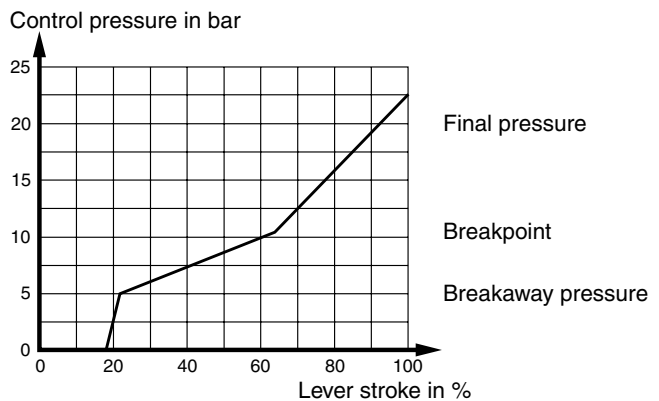

Diagram shows an example of a broken characteristic.

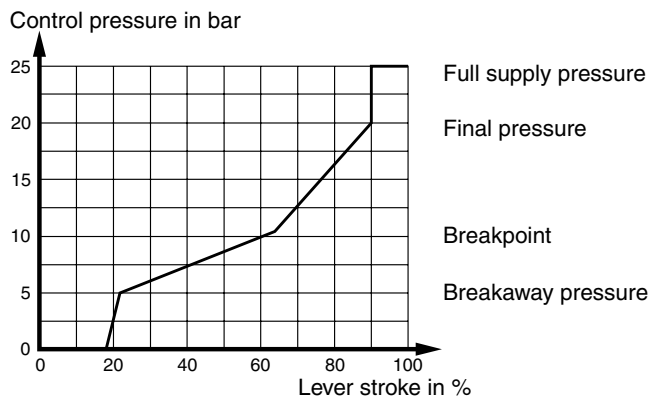

Diagram shows an example of a broken characteristic with overtravel stroke that gives full supply pressure.

Mounting plate

A number of different mounting plates for fitting the valve to the machine are available (see dimensional drawings).

- M1** Mounting plate for PCL401
- M2** Mounting plate for PCL402 with four control pressure ports
- M3** Mounting plate for PCL402
- M3S** Same as M3 but in Stainless steel
- M4** Mounting plate for PCL402 with two control pressure ports
- M5** Mounting plate for PCL402
- M6** Mounting plate for PCL402
- M9G** Mounting plate for PCL402 for Gresen replacement
- M10C** Mounting plate for PCL402 for Commercial replacement
- A102** Mounting plate for PCL401, rectangular bellows (for PCL401 with type N levers only)

Extra centring springs

Any control-pressure port can be fitted with an extra centring spring, which serves primarily to ensure centralization of the lever unit. (Heavier lever units need stronger centring springs.) Also, by fitting different springs at different ports, a coordinate lever (for instance) can be given different actuation resistances for different functions. A list of the different springs available is given in the table below, together with their respective force increases on the push rod. These force values should not be confused with the inherent lever forces, since the various activating devices have different ratios. F1 is the force transmission on the activating device when the spool is in the neutral position. F2 is the force transmission on a fully actuated activating device.

	F1	F2
C7	5 N	8 N
C0	19 N	33 N
C1	25 N	45 N
C5	35 N	71 N
C2	49 N	71 N
C3	51 N	92 N
C4	65 N	169 N
C6	100 N	214 N
C8	130 N	243 N

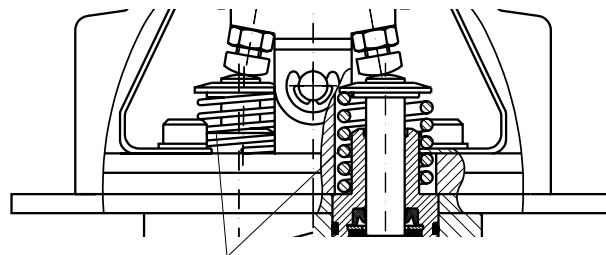

Extra centring spring

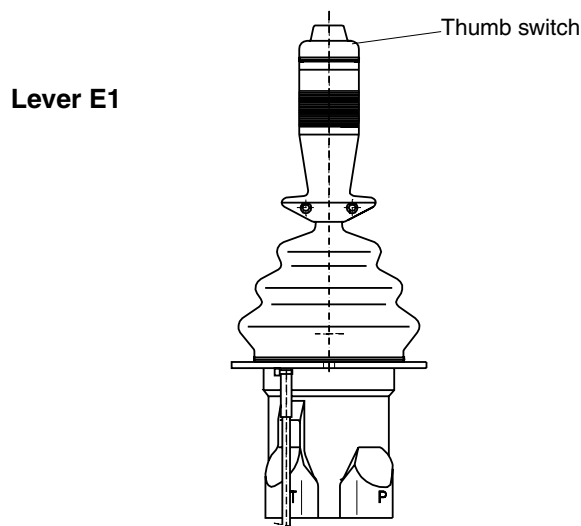

Lever E1

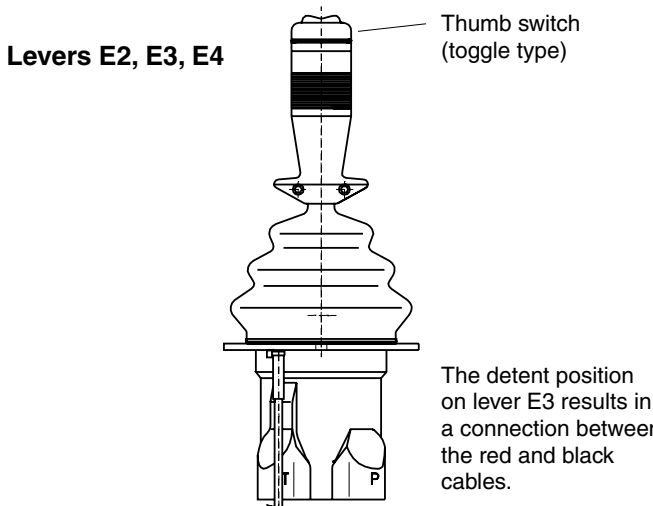
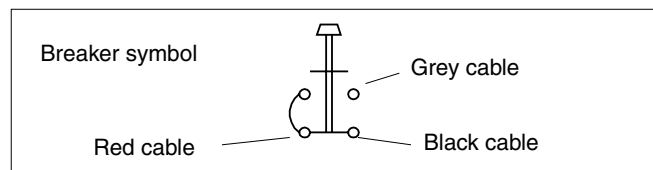

Levers E2, E3, E4

The detent position on lever E3 results in a connection between the red and black cables.

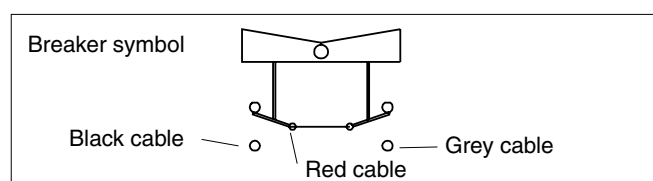

Activating devices

Several different types of activating device are available:

- Straight lever with ball
- Straight lever with window knob for insertion of functional symbol
- Straight lever with thicker plastic handle (can be equipped with different switches)
- Ergonomic multi-function lever that can be equipped with up to 5 thumb-switches
- Pedal

See also dimensional drawings.

- H1** Coordinate lever (joystick) with ball or window knob
- H3** Straight linear lever with ball or window knob
- H3S** Lever H3 in stainless steel
- H4-H7** Bent linear lever with ball or window knob
- E0** Linear or coordinate lever without thumb switch
- E1** Linear or coordinate lever with 2-position thumb switch
- E2** Linear or coordinate lever with 3-position, spring-centred toggle switch
- E3** Linear or coordinate lever with 3-position toggle switch with detent at one end position
- E4** Linear or coordinate lever with 3-position toggle switch with detents at both end positions
- N0** Coordinate lever without thumb switch
- N2** Coordinate lever with 2 instantaneous switches (Nos. 1 and 2)
- N2T** Coordinate lever with 3 instantaneous switches (Nos. 1, 2 and 5)
- N4** Coordinate lever with 4 instantaneous switches (Nos. 1-4)
- N4T** Coordinate lever with 5 instantaneous switches (Nos. 1-5)
- F** Pedal of pressed steel plate
- A36** Pedal of cast aluminium
- A95** Pedal of rubber coated steel

Lever N2T

right-hand version

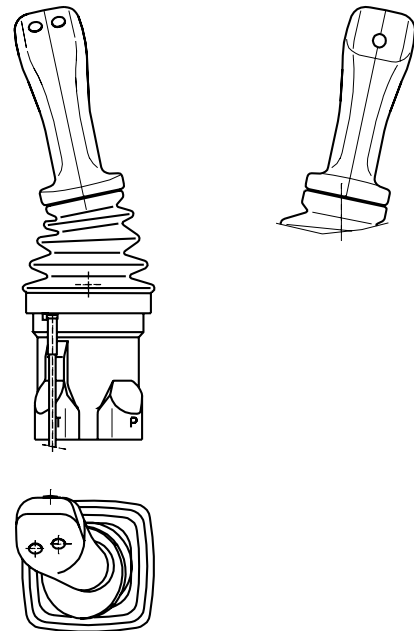

Right-hand version of lever, i.e. intended for mounting in right-hand arm rest.

Lever N4T

left-hand version

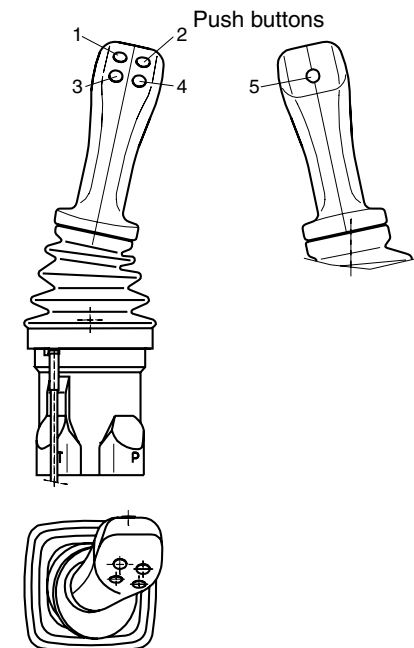

Left-hand version of lever, i.e. intended for mounting in left-hand arm rest.

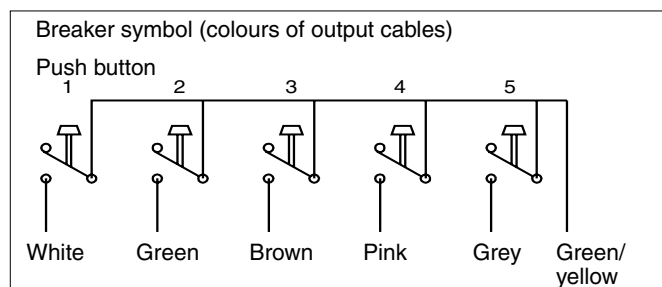

Lever detents for PCL402

Linear levers can be equipped with a detent that locks the lever in the fully actuated position (for one or both control-pressure ports).

MD2 Mechanical end-position detent. Released by pulling the lever out of its detented position. It can be used with signal pressures of up to 30 bar inclusive. See figure on page 6.

ED2 Electric end-position detent. A solenoid locks the lever in its fully actuated position. By means of a force index, a greater resistance to lever actuation is felt by the operator just before the lever enters the detented position, i.e. after approx. 75% of the lever stroke. The lever is released from the detented position by breaking the current to the solenoid. In emergencies, the lever can be pulled out of the detented position manually. Since sections equipped with the ED2 do not have protective bellows, it is important that they are installed in the machine in such a way as to prevent the ingress of dirt (which would impair the function of the valve).

At a signal pressure of 35 bar, the holding force is min. 19 N.

Electrical data:

Solenoid voltage: 24 VDC max. 3.2 W 100% ED

Index that gives increased resistance to lever actuation just before the solenoid locks the lever into the detented position.

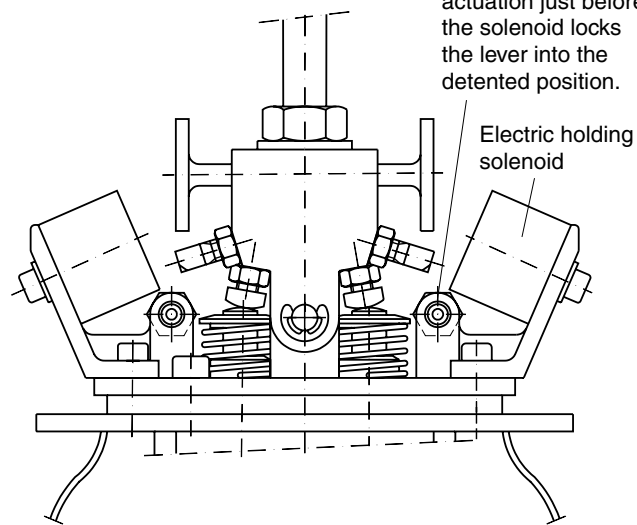

ED2 - electric end-position detent.

Friction brake for PCL402

S2 Friction brake with centre-position indication. Movement is braked so that the lever remains in any position in which it is put. The centre position is index-marked for reliable positioning into neutral. Due to the size of friction brake, a 35 mm spacer block is fitted between the sections in valves containing more than one section. See dimensional drawing.

Index that indicates when lever is in neutral

Brake unit

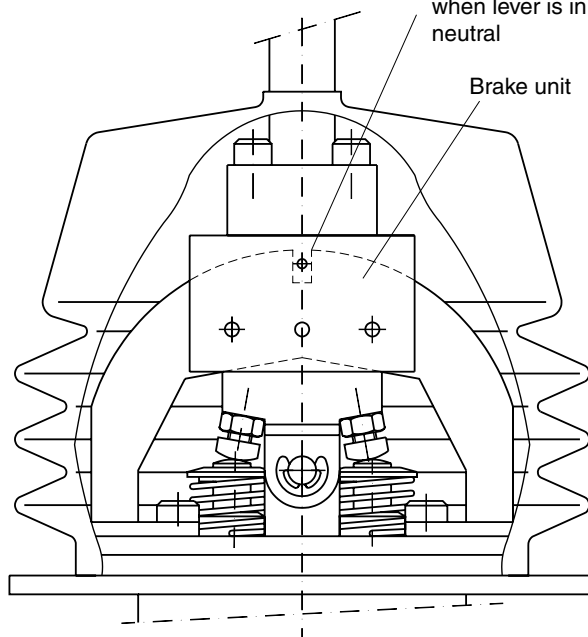

S2 - friction brake with centre-position indication.

Shuttle valve for signal on activation of valve

A42 PCL402 with 2 control-pressure ports, and with the pump and tank connections on the underside of the valve, can be equipped with a shuttle valve that emits a signal as soon as the valve is activated.

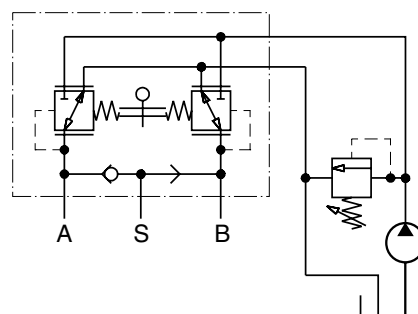

Signal obtained in port S on activation of valve.

PCL401 levers

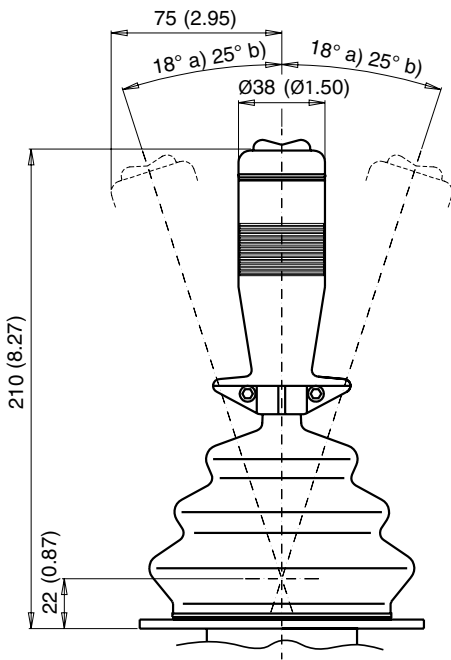

Lever E0 - E4

- a) Applies to max. actuation of one function
- b) Applies to max. actuation of two functions

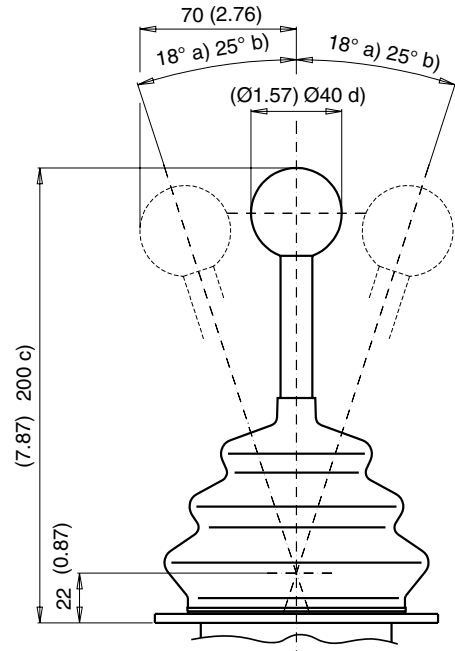

Lever H1 with ball

- c) 210 with window knob
- d) Ø27 with window knob

(inch)

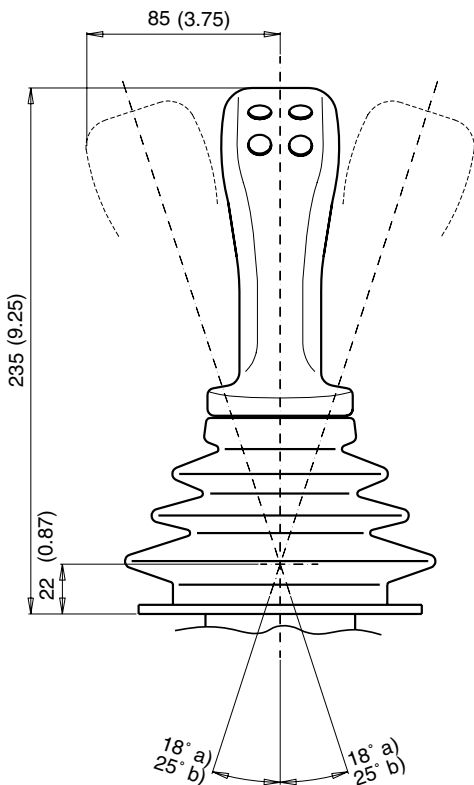

Lever N0 - N4T

Straight version

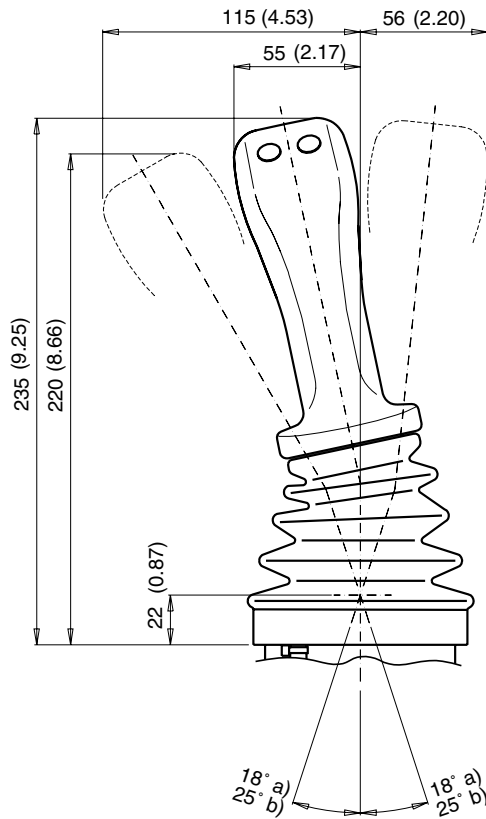

Lever N0 - N4T

Right-hand version and A102 mounting plate

PCL401 valve housing

PCL401 with all connections in the underside of the valve and with A102 mounting plate.

PCL401 with tank and pump connections on the side of the valve and with M1 mounting plate.

(inch)

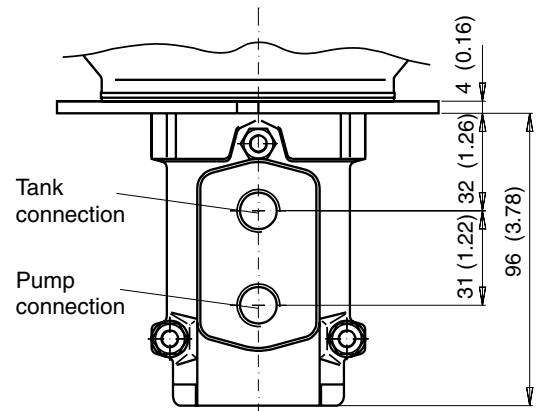
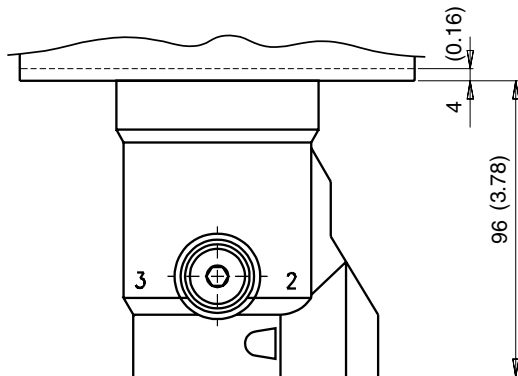
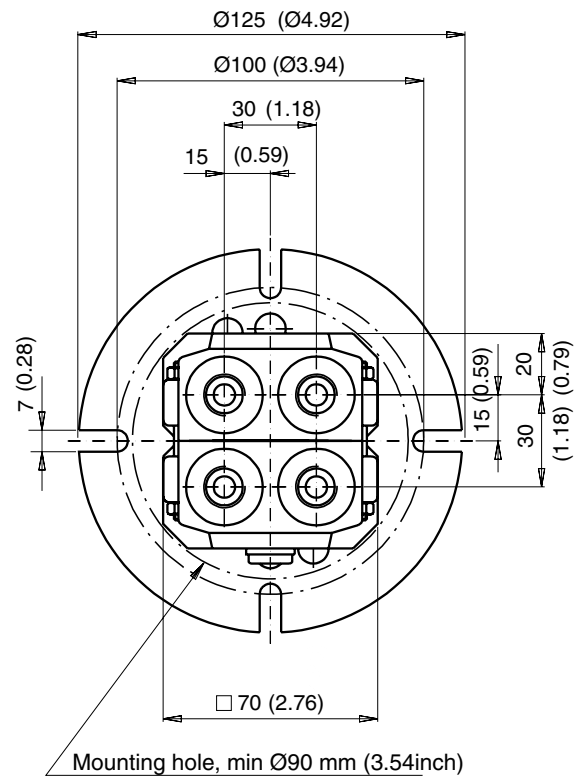
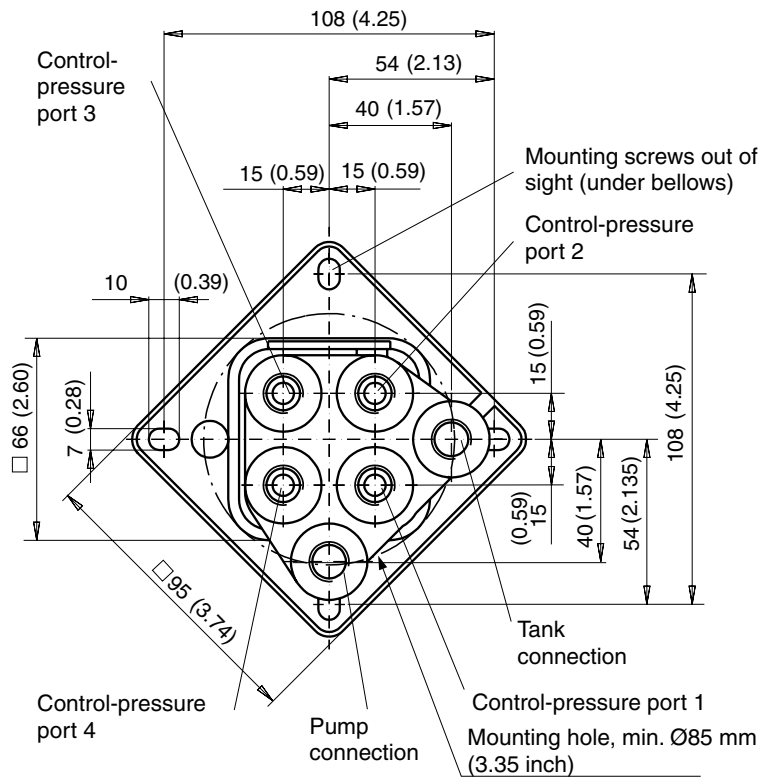

PCL402 Levers with ball

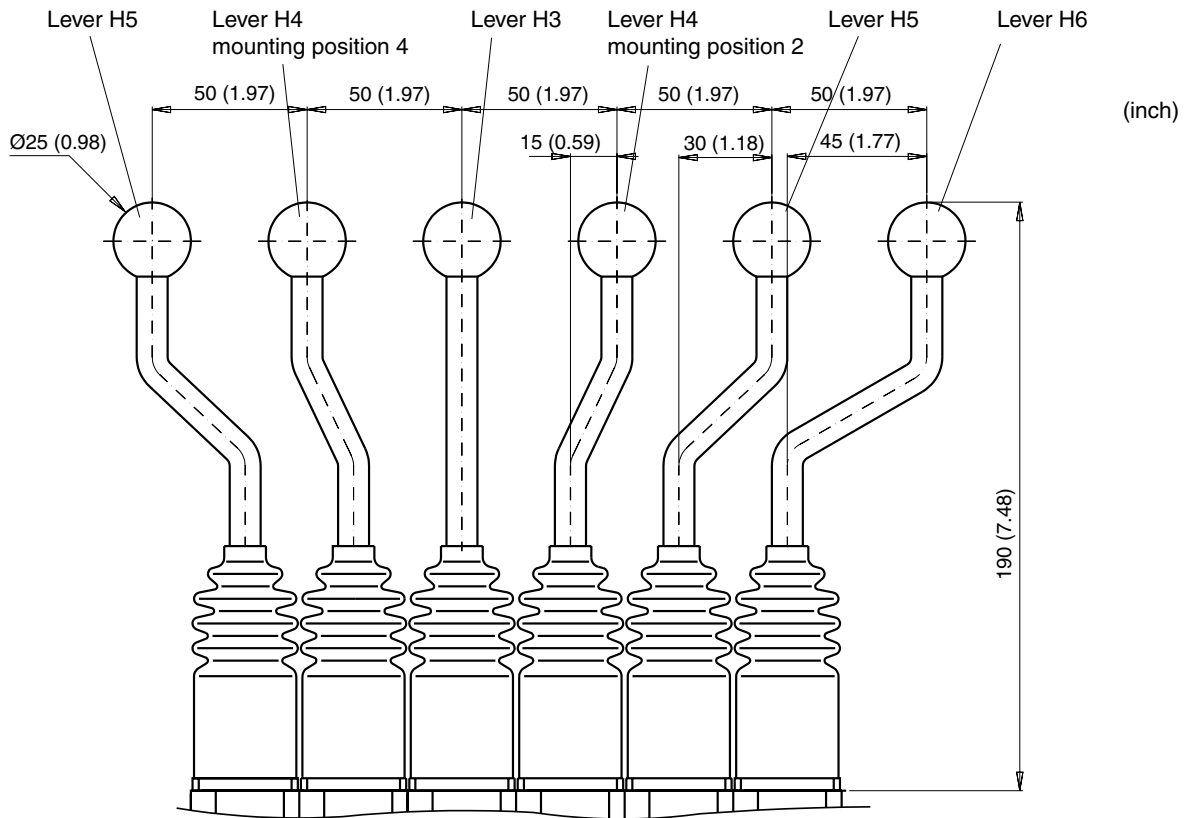

PCL402 with S2 friction brake on two sections

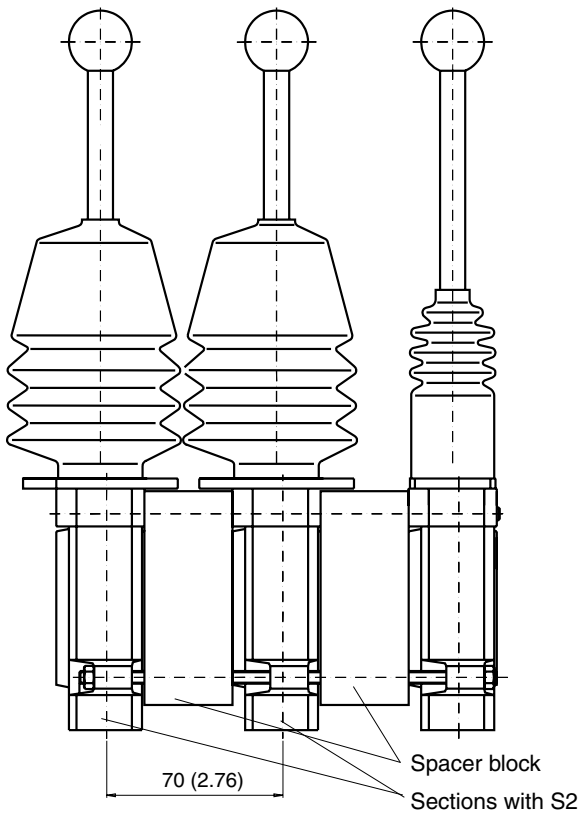

PCL402 with H3 lever and window knob

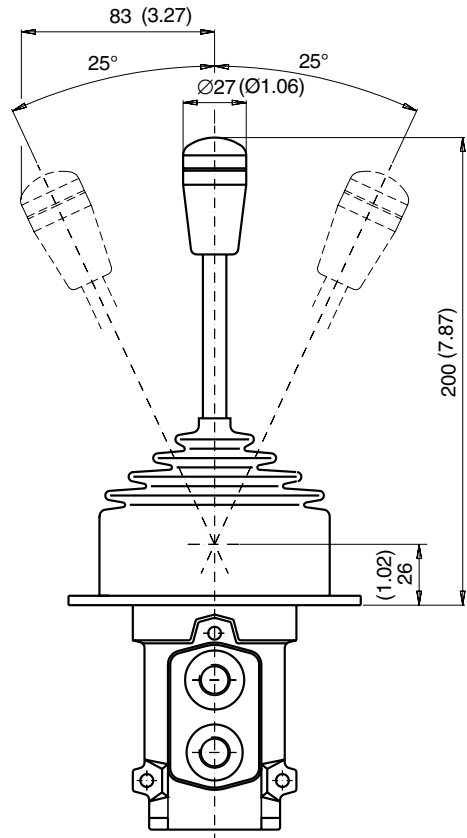

PCL402 Housing and mounting plates

M3 mounting plate

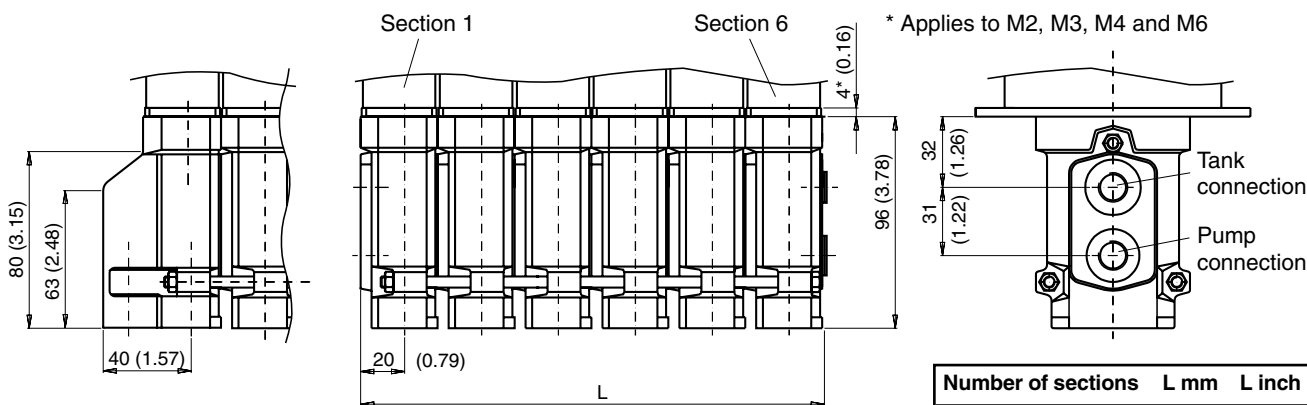
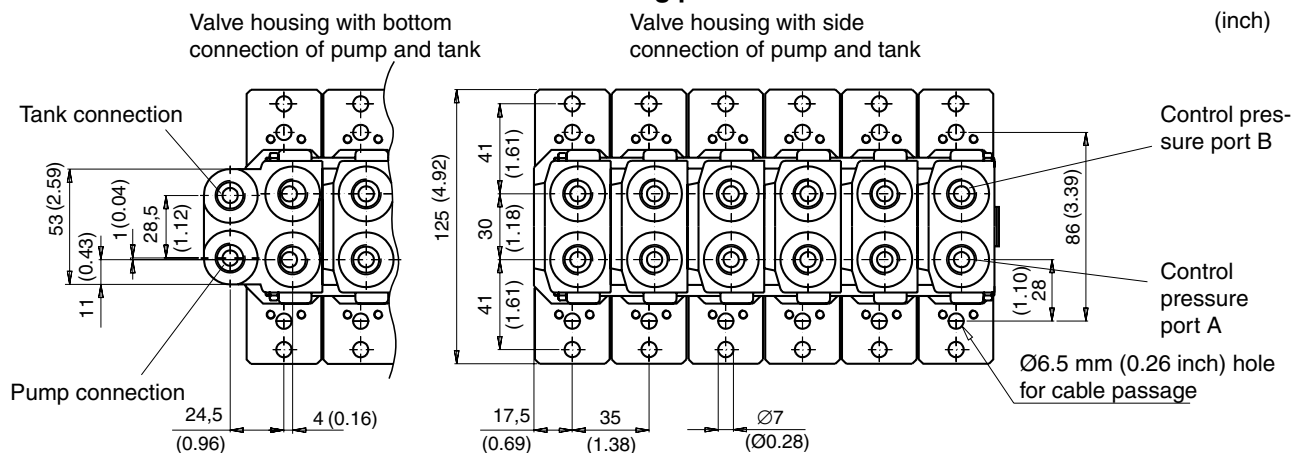

Number of sections	L mm	L inch
1	35	1.38
2	70	2.76
3	105	4.13
4	140	5.51
5	175	6.89
6	210	8.27

M2 mounting plate

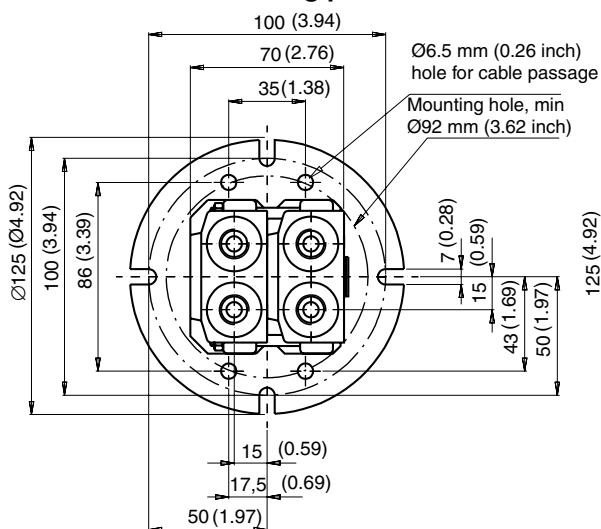

M4 mounting plate

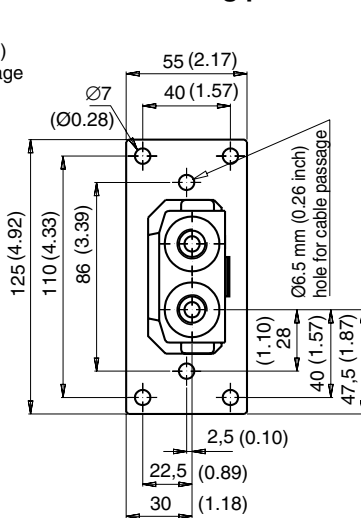

M6 mounting plate

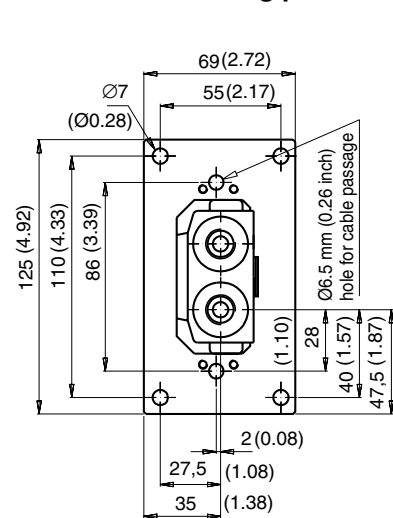

PCL402 Pedal F and M5 mounting plate

(inch)

For housing dimensions, see page 15

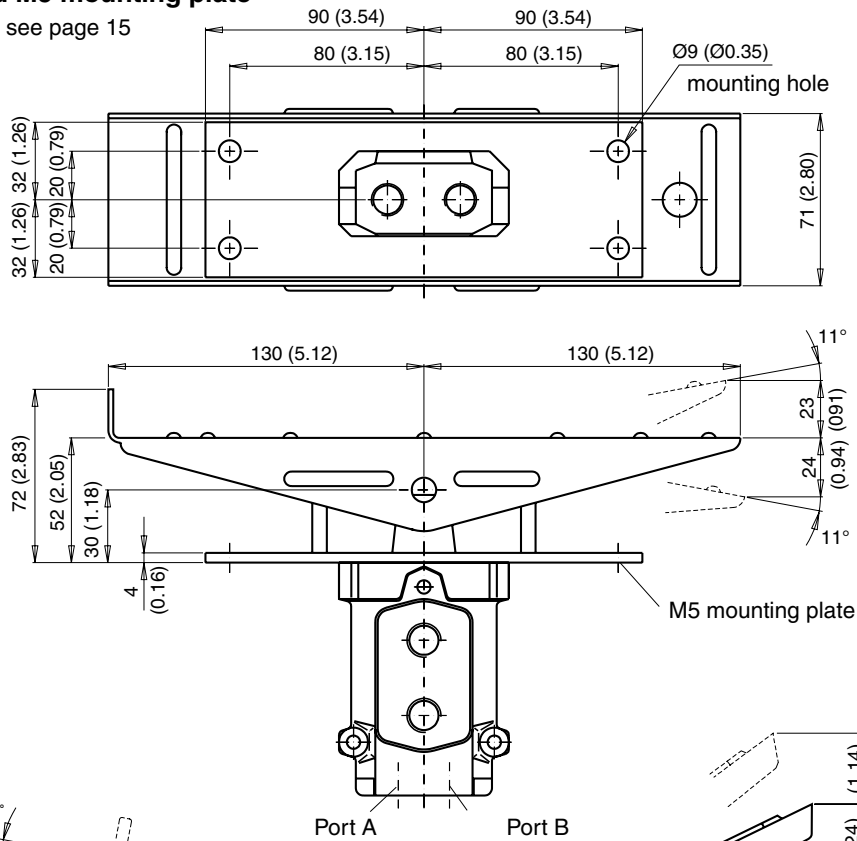

PCL402 Pedal A36

