



Integrated Hydrostatic Transmissions

HTE/HTJ/HTG Series
Catalog No. HY13-1595-002/US

aerospace
climate control
electromechanical
filtration
fluid & gas handling
hydraulics
pneumatics
process control
sealing & shielding



ENGINEERING YOUR SUCCESS.



WARNING

FAILURE OR IMPROPER SELECTION OR IMPROPER USE OF THE PRODUCTS AND/OR SYSTEMS DESCRIBED HEREIN OR RELATED ITEMS CAN CAUSE DEATH, PERSONAL INJURY AND PROPERTY DAMAGE.

This document and other information from Parker Hannifin Corporation, its subsidiaries and authorized distributors provide product and/or system options for further investigation by users having technical expertise. It is important that you analyze all aspects of your application and review the information concerning the product or system in the current product catalog. Due to the variety of operating conditions and applications for these products or systems, the user, through its own analysis and testing, is solely responsible for making the final selection of the products and systems and assuring that all performance, safety and warning requirements of the application are met.

The products described herein, including without limitation, product features, specifications, designs, availability and pricing, are subject to change by Parker Hannifin Corporation and its subsidiaries at any time without notice.

Offer of Sale

The items described in this document are hereby offered for sale by Parker Hannifin Corporation, its subsidiaries or its authorized distributors. This offer and its acceptance are governed by the provisions stated in the "Offer of Sale".

© 2012, Parker Hannifin Corporation, All Rights Reserved



Parker Hannifin Corporation
Hydraulic Pump/Motor Division
Greeneville, Tennessee, USA

Introduction	4
Features	5
HTE Series	
General Information	7
Ordering Information and Options	8–9
Ratings Table	10
Performance Data	11
Installation Dimensions	12–13
HTJ Series	
General Information	15
Ordering Information and Options	16–17
Ratings Table	18
Performance Data	19
Installation Dimensions	20–21
HTG Series	
General Information	23
Ordering Information and Options	24–25
Ratings Table	26
Performance Data	27
Installation Dimensions	28–29
Installation/Operation Information	30
Offer of Sale	31

Excellence of Design

The producers of Parker Hannifin's Integrated Hydrostatic Transmissions have a history of manufacturing reliable, precision parts that stretch back over a century. Milestones include the first patent on roller vane rotor sets for low speed, high torque hydraulic motors. That was forty years ago. Today, the technological advances continue.

In the Development Laboratory, engineers continuously measure and analyze pump and motor data to move existing products to even higher levels of performance, and develop new products that serve the ever changing needs of our customers. Design integrity is assured by exhaustive testing on endurance test stands. To be sure that this translates into superior performance, advanced manufacturing techniques are employed as well.

Excellence of Manufacturing

Central to manufacturing excellence is the understanding that quality parts make quality transmissions. The instrumentation in our Quality Assurance laboratory includes devices such as coordinate measuring machines, to accurately measure the parts that we manufacture as well as those that we purchase. Quality cannot be "inspected-in"; it must be manufactured. Each machine operator is responsible for the quality of the part that comes off that machine. Efficiency is enhanced by our cellular manufacturing techniques. Accuracy is assured by statistical process control methods. Micrometers and specialized gages are at the disposal of the operator. As a final check, every transmission is tested before shipment to our customer. Parker understands that our customers cannot produce quality products unless we do.

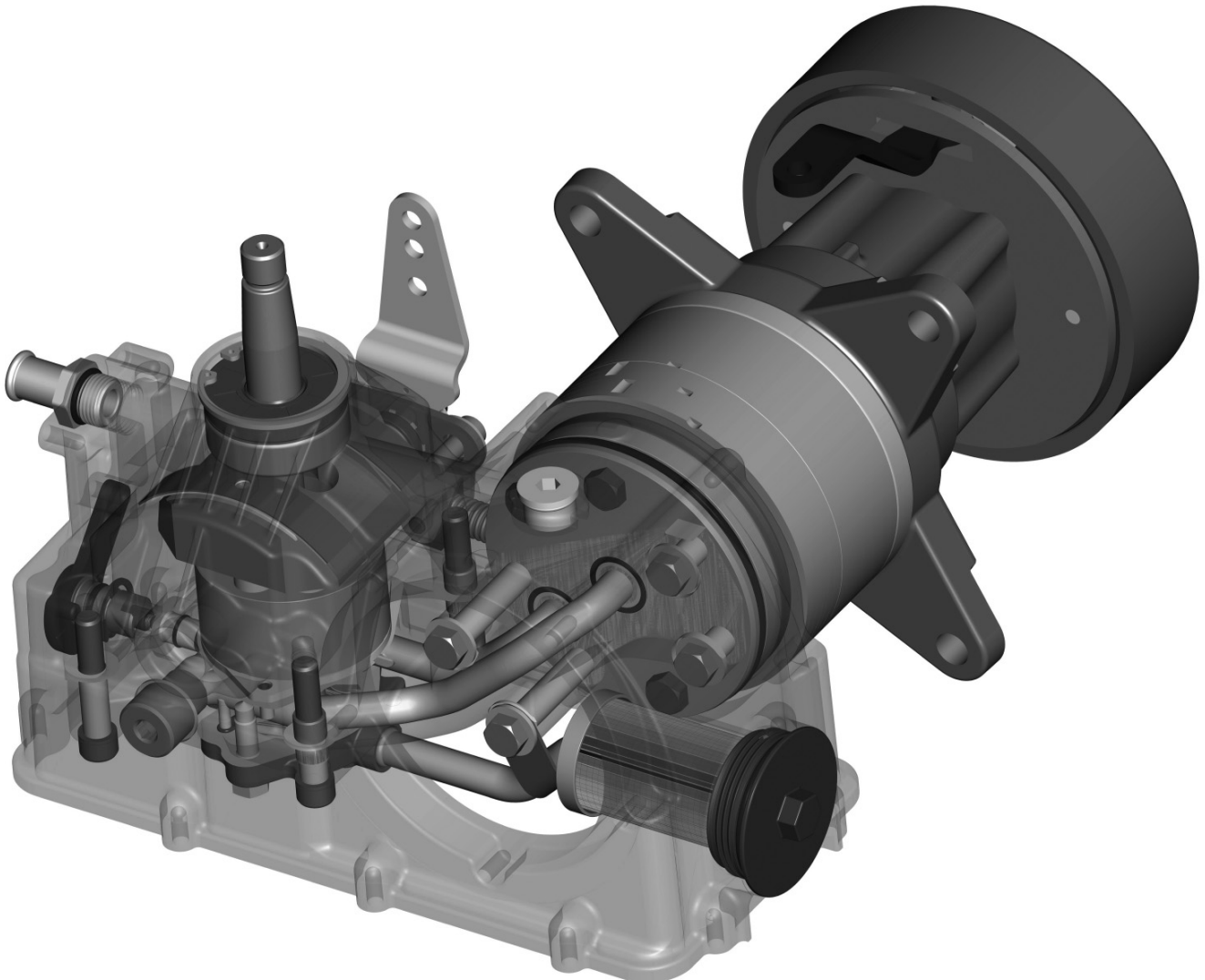

Parker's Integrated Hydrostatic Transmissions provide a compact, economical solution for the propulsion systems of off-highway vehicles up to 2500 pounds gross vehicle weight. One integrated package contains the hydrostatic pump, reservoir, filter and standard of the industry low speed, high torque motor. Bolt it to the vehicle, put on the wheels and you're ready to go.

And, your vehicle will be going with a transmission that performs with up to 10% more overall efficiency than competitive offerings. This means more horsepower to the deck or other functions, and more hill-climbing capability.

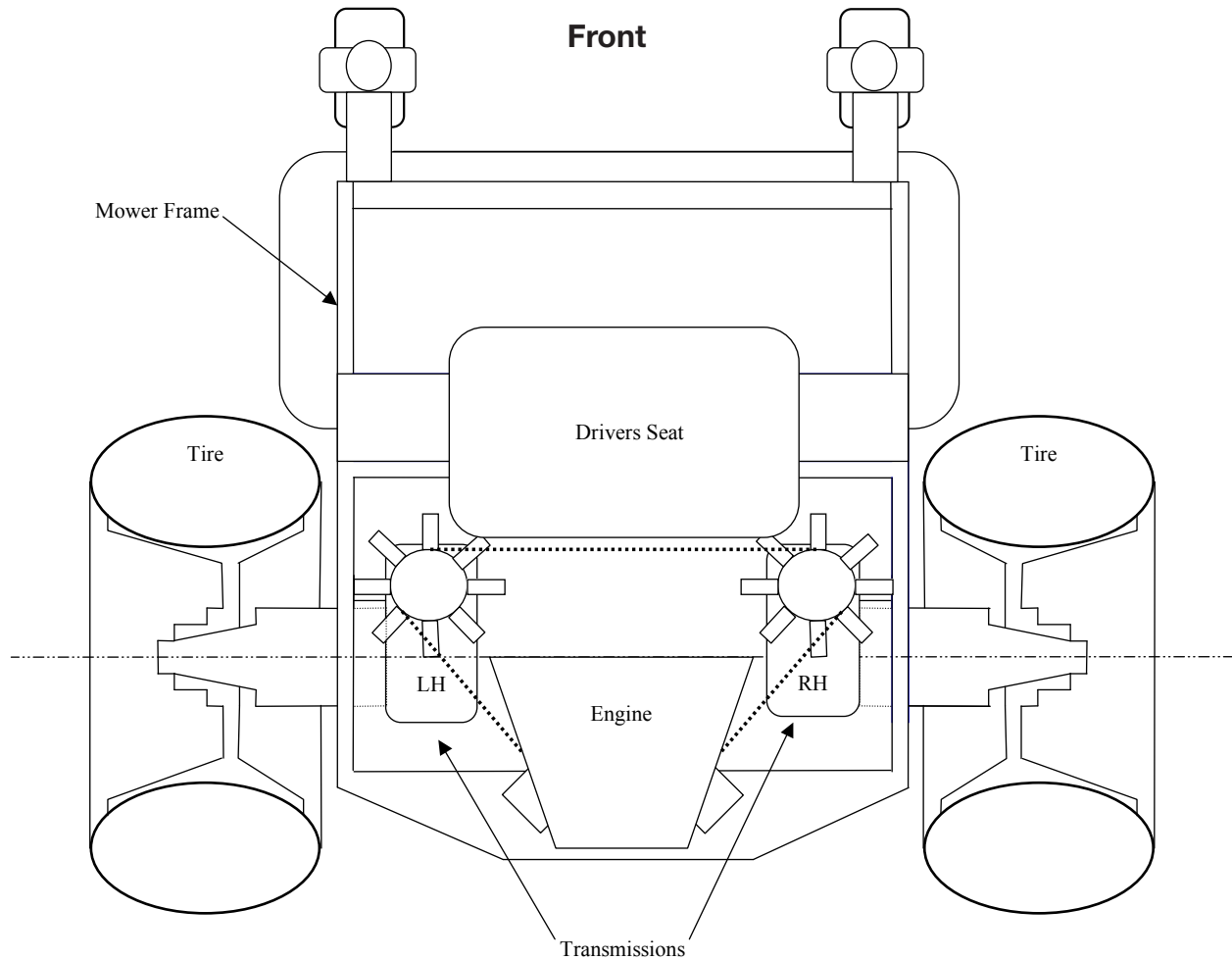

Page intentionally left blank

HTE Series Integrated Hydrostatic Transmission

Features

- Integrated pump/motor assembly
- Integral charge pump – 2.1 cc/rev
- Easy-to-service filter
- No expansion tank required
- Fan and pulley included
 - ◊ 5" pulley standard
 - 4" optional
 - ◊ 7" fan standard
 - 6" optional with 4" pulley
- Integral reservoir (approx 0.5 gal)
- Parking brake optional
- Fluid filled for life
- Return-to-neutral options
- Integral shock valves optional

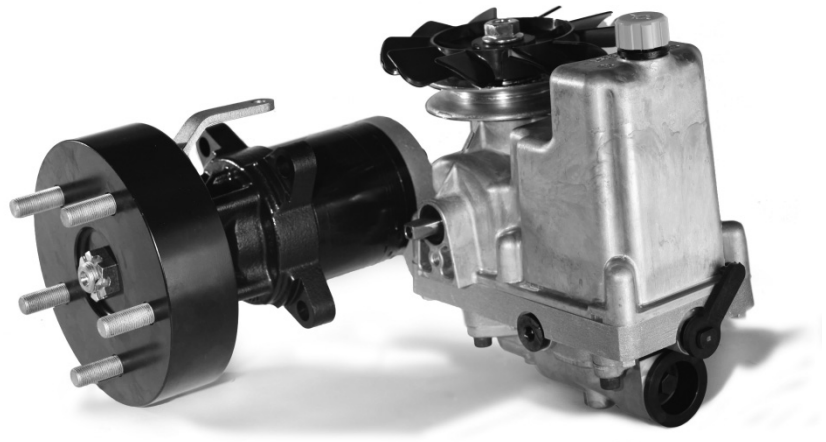

Schematic Symbol

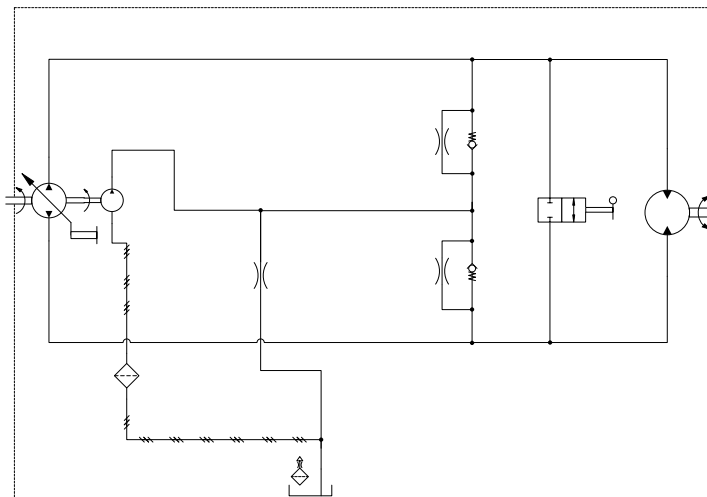

Pump

cc/rev	10.2
cu in/rev	0.623

Motors

130	163	195	228	260	293
8.0	10.0	11.9	13.9	15.9	17.9

HTE

HTE Series

XX

Pump Displacement

Code	cm ³ /rev	in ³ /rev
10	10.2	/ .62

X

Orientation

	Orientation
L	Left side transmission
R	Right side transmission

XXX

Motor Displacement

Code	cm ³ /rev	in ³ /rev
130	130	/ 8.0
165	163	/ 10.0
195	195	/ 11.9
230	228	/ 13.9
260	260	/ 15.9
295	293	/ 17.9

X

Control Arm

Code	Control Arm
A	No return-to-neutral (RTN)
B	RTN heavy spring / heavy spring
C	Control lever only

Shock Valves & Orifices



Wheel Hub



Brake Lever



Forward



Reverse



Option

Code	Wheel Hub
0	1" tapered output shaft
4	4-bolt hub
5	5-bolt hub

Code	Brake Lever
0	No brake
A	Drum Brake - two hole lever
B	Drum Brake - one-hole lever

Code	Option
AAAB	Unpainted – Motor subassembly painted, other surfaces left unpainted.

Code	Forward
N	Shock Valve - no orifice
M	Shock Valve - .018" orifice
L	Shock Valve - .024" orifice
K	Shock Valve - .031" orifice
J	Check Valve - no orifice
H	Check Valve - .018" orifice
G	Check Valve - .024" orifice
F	Check Valve - .031" orifice

Code	Forward
M	Shock Valve - .018" orifice
L	Shock Valve - .024" orifice
K	Shock Valve - .031" orifice
H	Check Valve - .018" orifice
G	Check Valve - .024" orifice
F	Check Valve - .031" orifice
E	Check Valve - .044" orifice

*Consult factory for other available shafts/valving/options.

Shaft Output Torque Ratings (per transmission)

Motor Displacement (cc/rev)	130	165	195	228	260	293
Continuous (lb in)	1580	1980	2415	2710	3140	3560
Minimum starting (lb in)	2420	2990	3635	3635	3975	3940
Maximum (lb in)	3115	3845	4675	4555	4870	5180

Shaft Output Speed Ratings (at 3600 rpm input speed / no-load condition)

Motor Displacement (cc/rev)	130	165	195	228	260	293
Output Speed (rpm)	265	212	177	152	133	118
Speed (mph) 18" Tire	13.4	10.7	8.9	7.7	6.7	6
Speed (mph) 20" Tire	15	12	10	8.6	7.5	6.7
Speed (mph) 22" Tire	16.6	13.3	11.1	9.5	8.3	7.4
Speed (mph) 24" Tire	18.1	14.5	12.1	10.4	9.1	8.1

Values for output speed (rpm) are theoretical at 95% volumetric efficiency.

Values for output speed (mph) use the calculated speed (rpm) values and assume a rolling radius of 0.5 inches less than one-half of the tire diameter.

Vehicle Ratings

For use with tires up to 24" diameter and gross vehicle weights (GVW) up to 1300 lb. See side load chart on page 11 for specific side load ratings.

**Brake holding torque capacity = 4000 lb-in per side
Transmission weight = 30 lb**

Radial Load

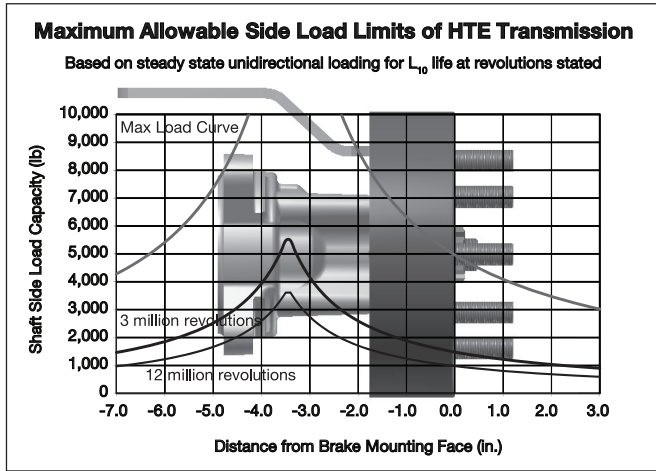

With Brake

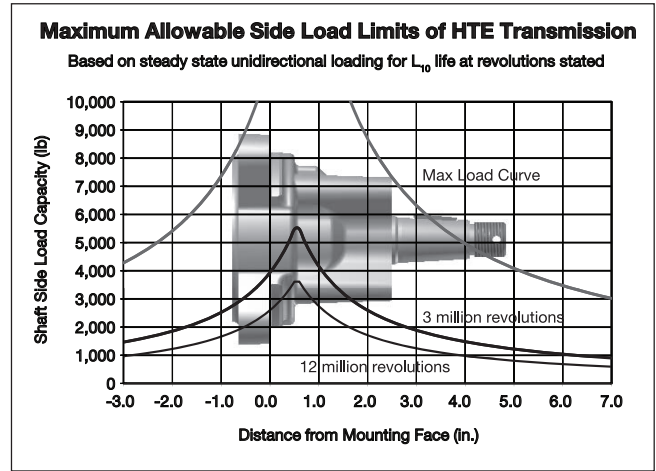

Without Brake

The dynamic side load curves are based on uni-directional steady state loads for L_{10} bearing life at stated number of revolutions. The maximum load curve is defined by bearing static load capacity. This curve should not be exceeded at any time including shock loads.

Equation to Calculate the Expected Radial Bearing Life

Equation to calculate the dynamic bearing life for a given load:

Use F_a , F_b and S in equation to determine hours of L_{10} bearing life.

$$L = \frac{3 \times 10^6}{60 \times S} \left\{ \frac{F_a}{F_b} \right\}^{3.33}$$

Where:

S = Shaft Speed RPM

L = Life In Hours

F_a = Dynamic side load defined by the 3 million revolutions curve at a distance from mounting flange.

F_b = Application side load.

Note: Calculations are based on L_{10} bearing life per ISO 281.

5-Bolt Hub

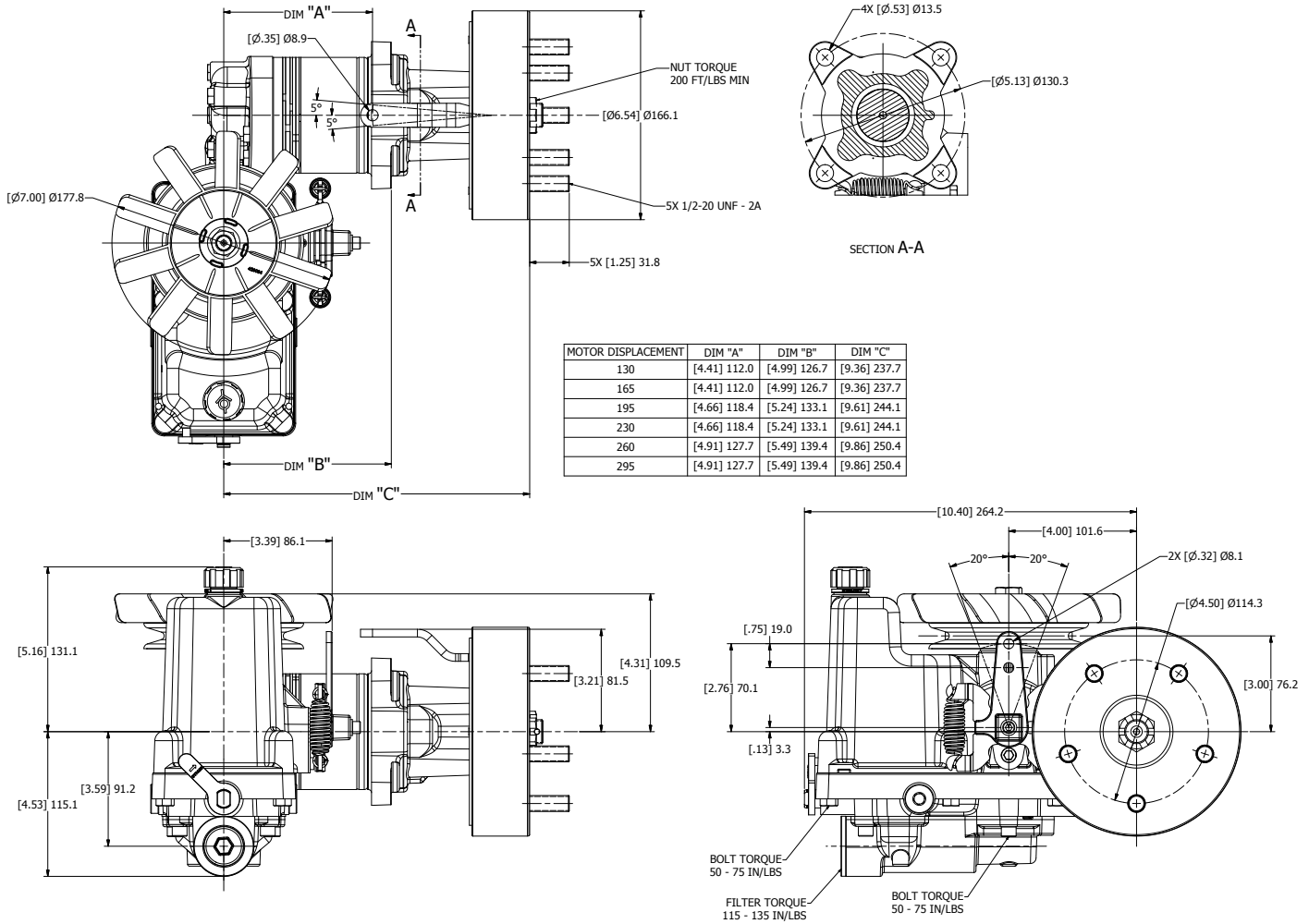

- HTE shown with:
 - 5-bolt hub
 - 7" fan
 - 5" pulley
 - Return-to-neutral mechanism

English equivalents for metric specifications are shown in ().

4-Bolt Hub

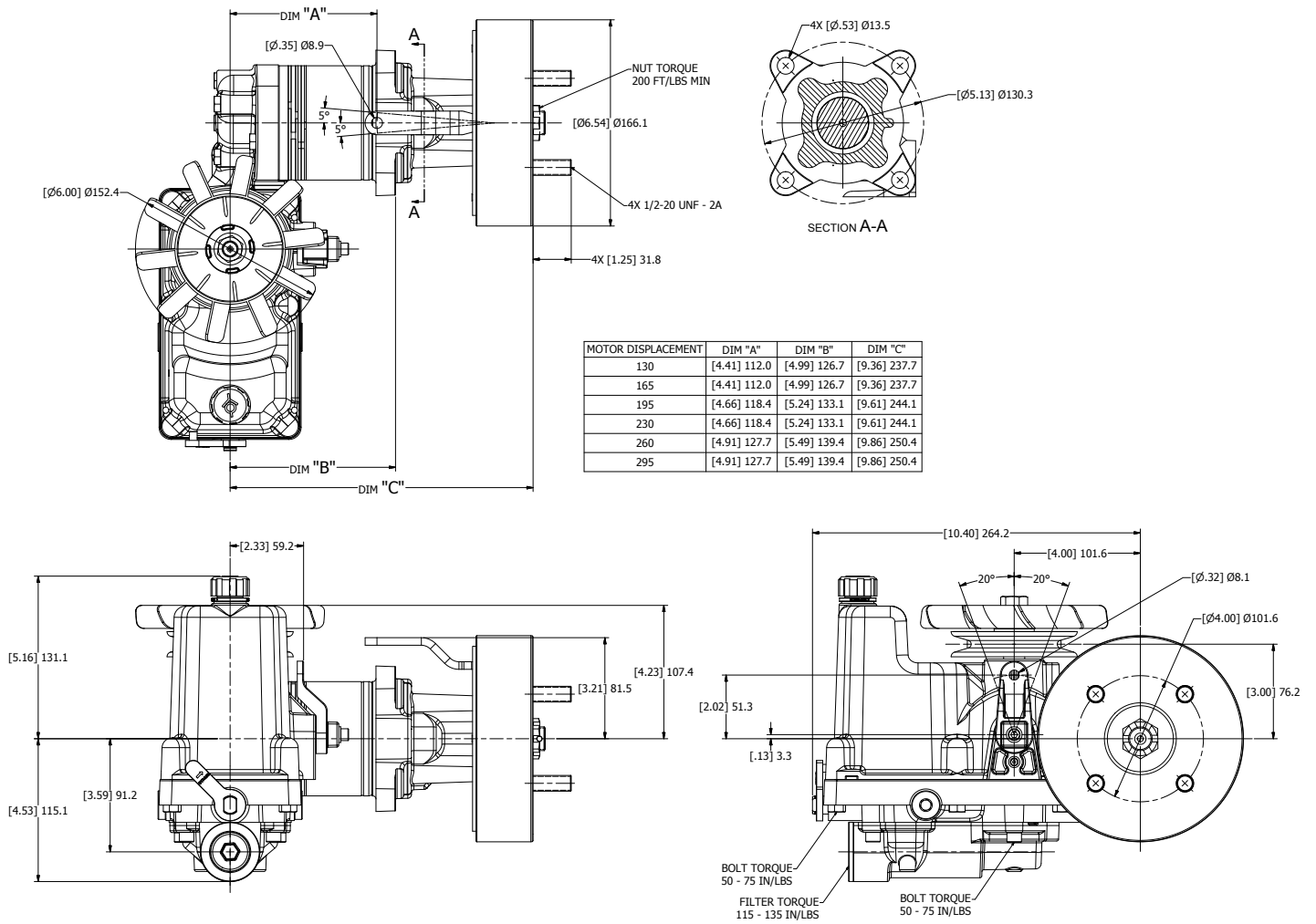

- HTE shown with:
 - 4-bolt hub
 - 6" fan
 - 4" pulley
 - Control arm / no return-to-neutral mechanism

English equivalents for metric specifications are shown in ().

Page intentionally left blank

HTJ Series Integrated Hydrostatic Transmission

Features

- Integrated pump/motor assembly
- Integral charge pump – 2.1 cc/rev
- Easy-to-service filter
- No expansion tank required
- Fan and pulley included
 - ◊ 5" pulley standard
 - 4" optional
 - ◊ 7" fan standard
 - 6" optional with 4" pulley
- Integral reservoir (approx 0.5 gal)
- Parking brake optional
- Easy fluid change
- Return-to-neutral options
- Integral shock valves optional

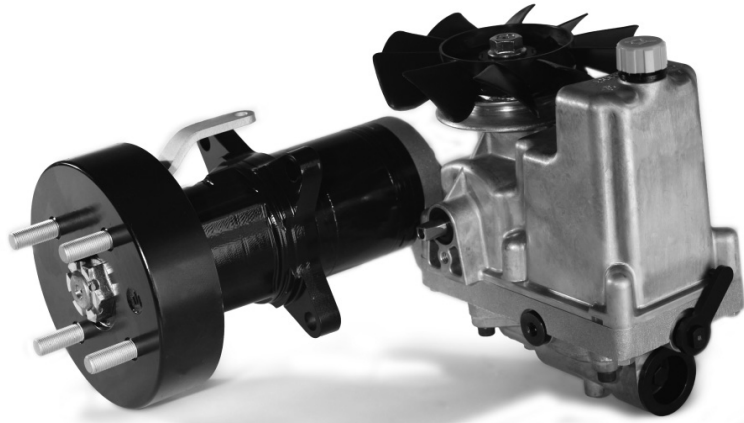

Schematic Symbol

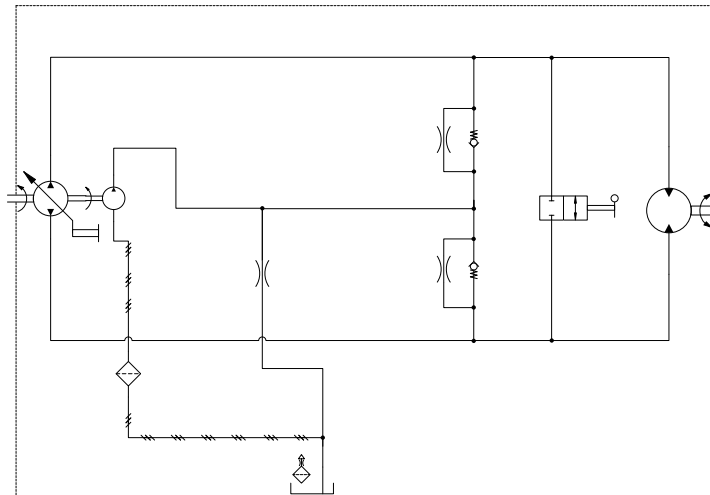

Pump

cc/rev	10.2
cu in/rev	0.623

Motors

130	163	195	228	260	293
8.0	10.0	11.9	13.9	15.9	17.9

HTJ

HTJ Series

XX

Pump Displacement

Code	cm ³ /rev	in ³ /rev
10	10.2	/ .62

X

Orientation

	Orientation
L	Left side transmission
R	Right side transmission

XXX

Motor Displacement

Code	cm ³ /rev	in ³ /rev
130	130	/ 8.0
165	163	/ 10.0
195	195	/ 11.9
230	228	/ 13.9
260	260	/ 15.9
295	293	/ 17.9

X

Control Arm

Code	Control Arm
A	No return-to-neutral (RTN)
B	RTN heavy spring / heavy spring
C	Control lever only

Shock Valves & Orifices



Wheel Hub



Brake Lever



Forward



Reverse



Option



Code	Wheel Hub
0	1-1/4" tapered output shaft
4	4-bolt hub
5	5-bolt hub



Code	Brake Lever
0	No brake
A	Drum Brake - two hole lever
B	Drum Brake - one-hole lever



Code	Forward
N	Shock Valve - no orifice
M	Shock Valve - .018" orifice
L	Shock Valve - .024" orifice
K	Shock Valve - .031" orifice
J	Check Valve - no orifice
H	Check Valve - .018" orifice
G	Check Valve - .024" orifice
F	Check Valve - .031" orifice



Code	Forward
M	Shock Valve - .018" orifice
L	Shock Valve - .024" orifice
K	Shock Valve - .031" orifice
H	Check Valve - .018" orifice
G	Check Valve - .024" orifice
F	Check Valve - .031" orifice
E	Check Valve - .044" orifice

Code	Option
AAAB	Unpainted – Motor subassembly painted, other surfaces left unpainted.

*Consult factory for other available shafts/valving/options.

Shaft Output Torque Ratings (per transmission)

Motor Displacement (cc/rev)	130	165	195	228	260	293
Continuous (lb in)	1580	1980	2415	2710	3140	3560
Minimum starting (lb in)	2420	2990	3635	3635	3975	3940
Maximum (lb in)	3115	3845	4675	4555	4870	5180

Shaft Output Speed Ratings (at 3600 rpm input speed / no-load condition)

Motor Displacement (cc/rev)	130	165	195	228	260	293
Output Speed (rpm)	265	212	177	152	133	118
Speed (mph) 18" Tire	13.4	10.7	8.9	7.7	6.7	6
Speed (mph) 20" Tire	15	12	10	8.6	7.5	6.7
Speed (mph) 22" Tire	16.6	13.3	11.1	9.5	8.3	7.4
Speed (mph) 24" Tire	18.1	14.5	12.1	10.4	9.1	8.1

Values for output speed (rpm) are theoretical at 95% volumetric efficiency.

Values for output speed (mph) use the calculated speed (rpm) values and assume a rolling radius of 0.5 inches less than one-half of the tire diameter.

Vehicle Ratings

For use with tires up to 24" diameter and gross vehicle weights (GVW) up to 1600 lb. See side load chart on page 19 for specific side load ratings.

Brake holding torque capacity = 4000 lb-in per side
Transmission weight = 32 lb

Radial Load

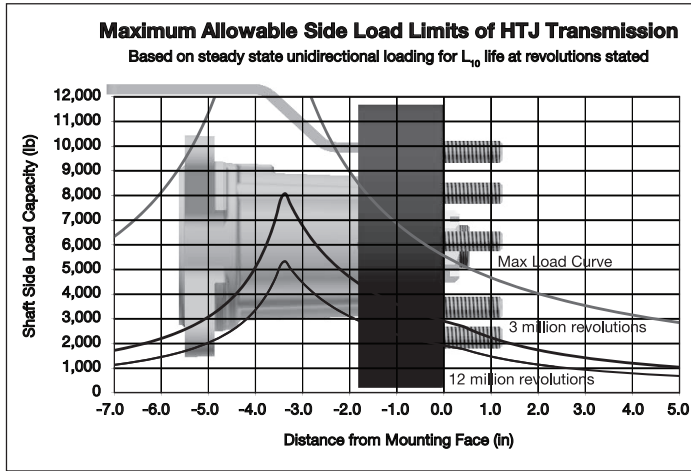

With Brake

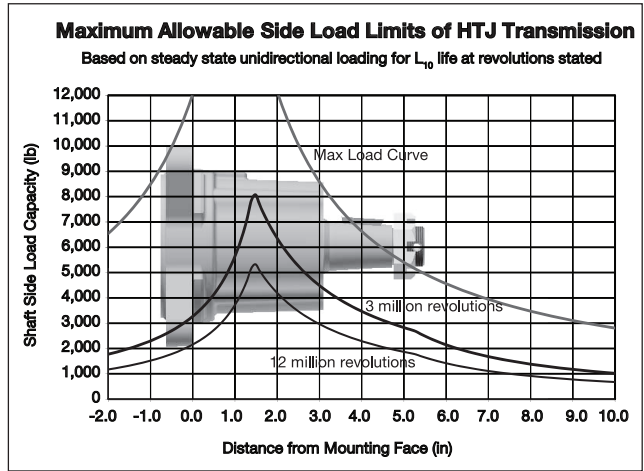

Without Brake

The dynamic side load curves are based on uni-directional steady state loads for L_{10} bearing life at stated number of revolutions. The maximum load curve is defined by bearing static load capacity. This curve should not be exceeded at any time including shock loads.

Equation to Calculate the Expected Radial Bearing Life

Equation to calculate the dynamic bearing life for a given load:

Use F_a , F_b and S in equation to determine hours of L_{10} bearing life.

$$L = \frac{3 \times 10^6}{60 \times S} \left\{ \frac{F_a}{F_b} \right\}^{3.33}$$

Where:

S = Shaft Speed RPM

L = Life In Hours

F_a = Dynamic side load defined by the 3 million revolutions curve at a distance from mounting flange.

F_b = Application side load.

Note: Calculations are based on L_{10} bearing life per ISO 281.

5-Bolt Hub

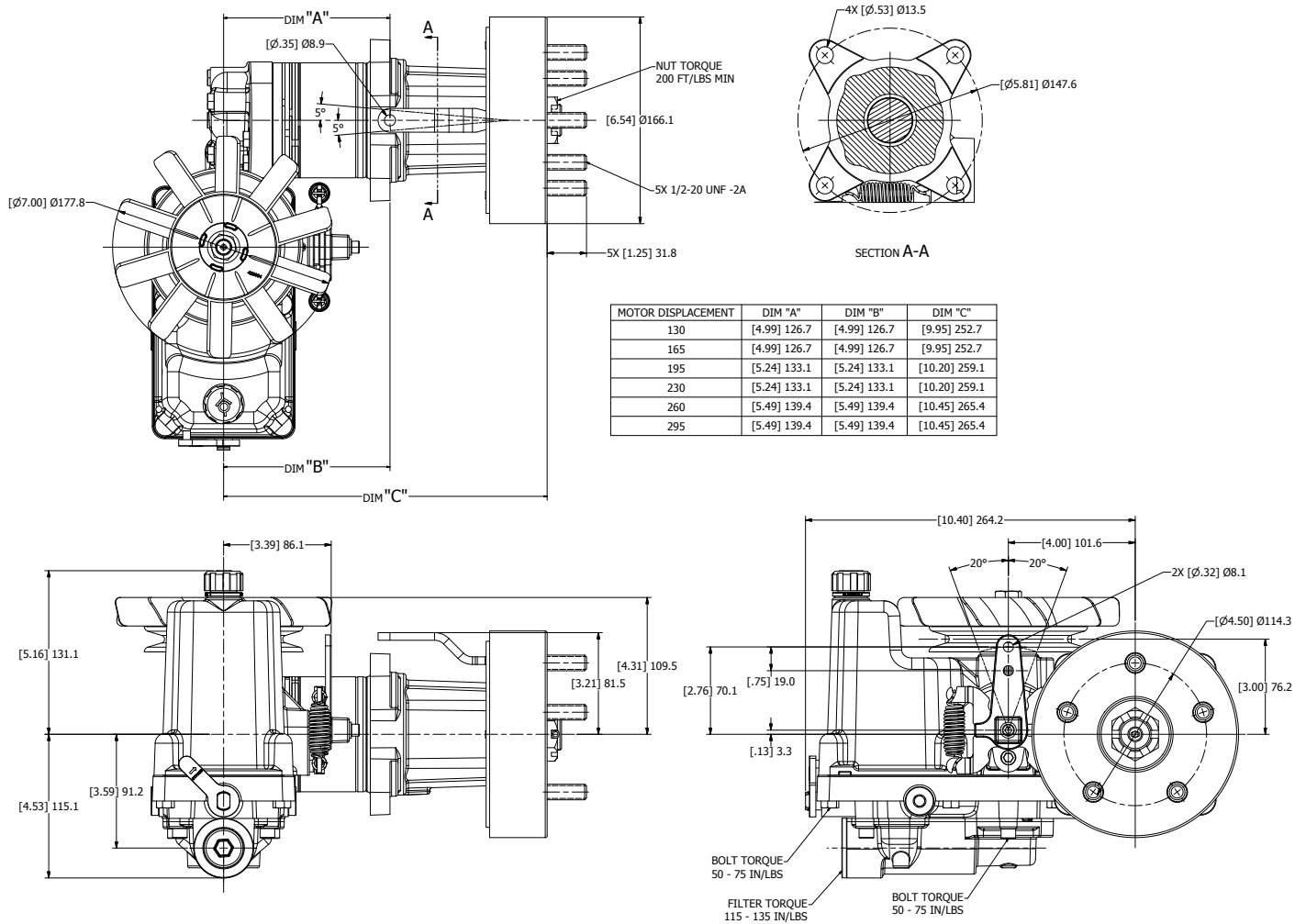

- HTJ shown with:
 - 5-bolt hub
 - 7" fan
 - 5" pulley
 - Return-to-neutral mechanism

English equivalents for metric specifications are shown in ().

4-Bolt Hub

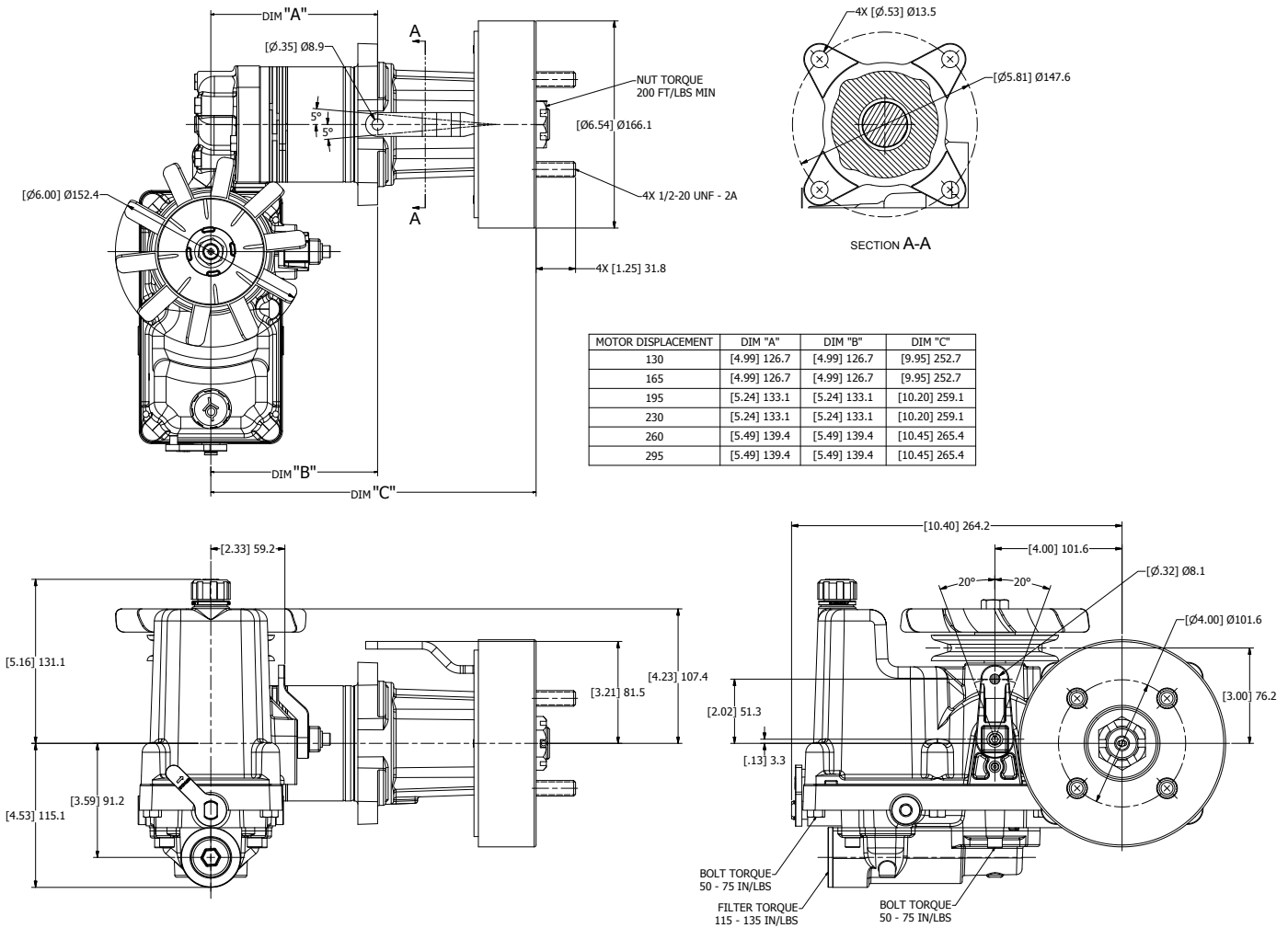

- HTJ shown with:
 - 4-bolt hub
 - 6" fan
 - 4" pulley
 - Control arm / no return-to-neutral mechanism

English equivalents for metric specifications are shown in ().

Page intentionally left blank

HTG Series Integrated Hydrostatic Transmission

Features

- Integrated pump/motor assembly
- Integral charge pump – 2.1 cc/rev
- Easy-to-service filter
- Remote expansion tank required
- Fan and pulley included
 - ◊ 6" pulley standard
 - ◻ 5" optional with 14cc pump
 - ◊ 8.3" fan standard
- Integral reservoir (approx 0.8 gal)
- Parking brake optional
- Easy fluid change
- Return-to-neutral options
- Integral shock valves standard



Schematic Symbol

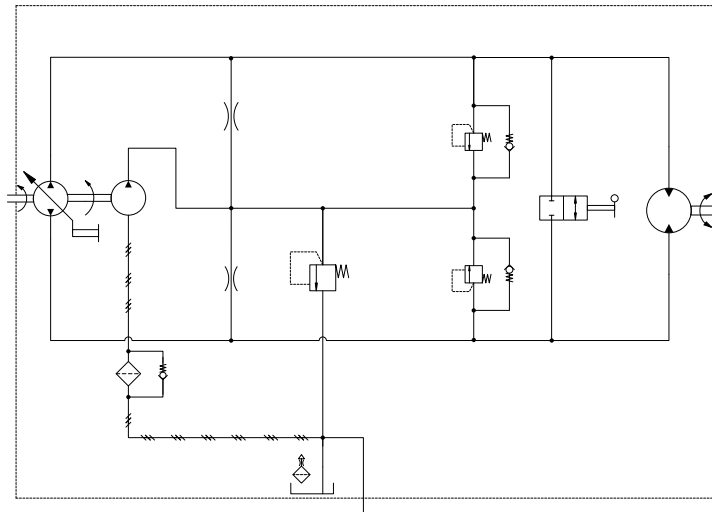

Pump

cc/rev	14.1	16
cu in/rev	0.854	0.976

Motors

238	280	310
14.5	17.1	18.9

HTG

HTG Series

XX

Pump Displacement

Code	cm ³ /rev	in ³ /rev
14	14.1 /	.854
16	16.0 /	.976

X

Orientation

	Orientation
L	Left side transmission
R	Right side transmission

XXX

Motor Displacement

Code	cm ³ /rev	in ³ /rev
240	238 /	14.5
280	280 /	17.1
310	310 /	18.9

X

Control Arm

Code	Control Arm
A	No return-to-neutral (RTN)
B	RTN heavy spring / heavy spring
C	Control lever only

Shock Valves & Orifices

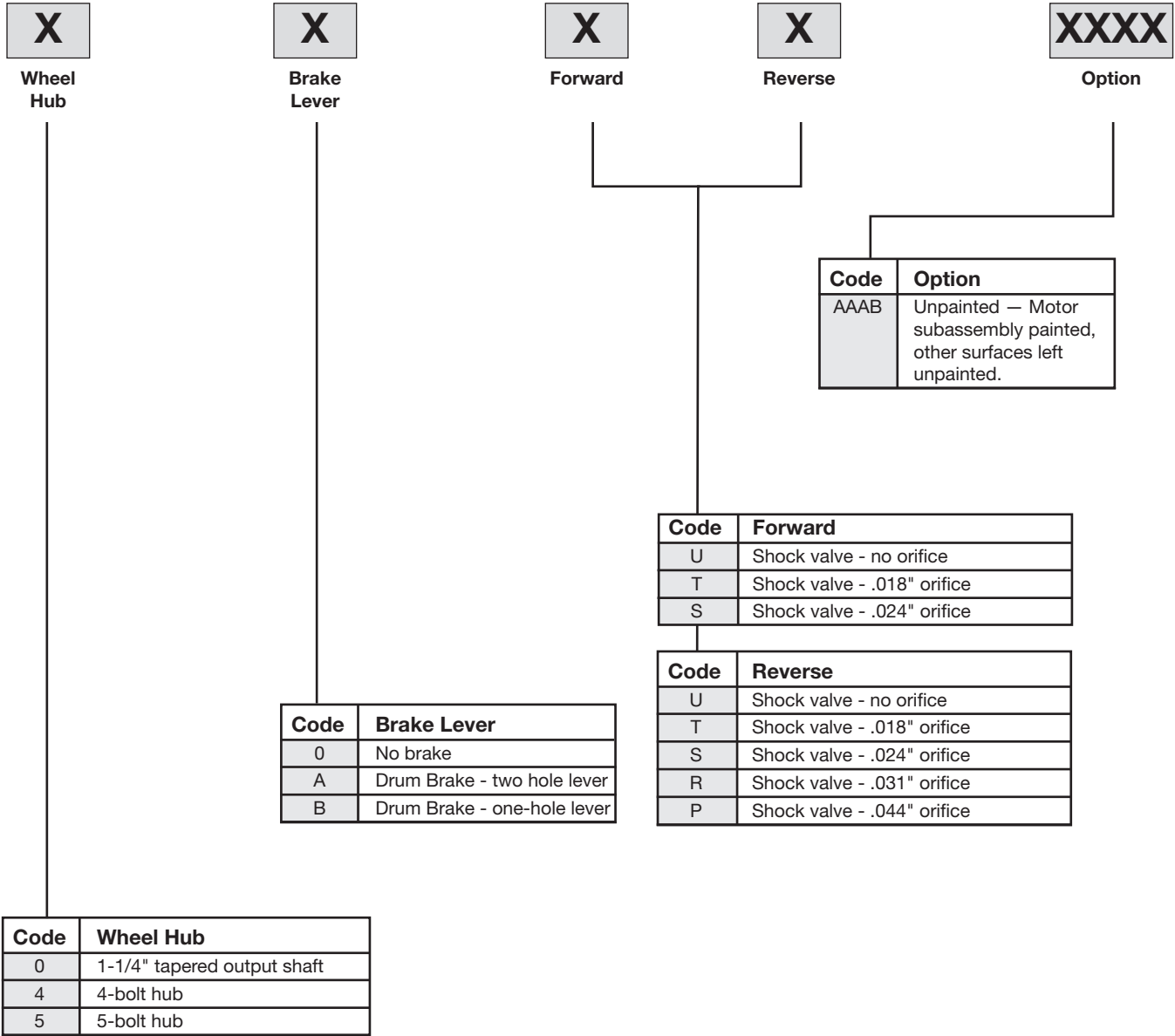

*Consult factory for other available shafts/valving/options.

Shaft Output Torque Ratings (per transmission)

Motor Displacement (cc/rev)	Continuous Output Torque Rating (lb-in)			Minimum Starting Torque (lb-in)			Maximum Output Torque Rating (lb-in)			
	240	280	310	240	280	310	240	280	310	
Pump Displacement (cc/rev)	14	3090	3590	4250	5150	5970	6880	5990	7040	8180
	16	2680	3110	3680	5150	5970	6880	5990	7040	8180

Shaft Output Speed Ratings (at 3600 rpm input speed / no-load condition)

Motor Displacement (cc/rev)	Output Speed (rpm)			Speed (mph) 23" Tire			Speed (mph) 24" Tire			
	240	280	310	240	280	310	240	280	310	
Pump Displacement (cc/rev)	14	200	171	154	13.1	11.2	10.1	13.7	11.7	10.6
	16	228	195	177	14.9	12.8	11.6	15.6	13.4	12.1

Motor Displacement (cc/rev)	Speed (mph) 25" Tire			Speed (mph) 26" Tire			
	240	280	310	240	280	310	
Pump Displacement (cc/rev)	14	—	12.2	11.0	—	—	11.5
	16	—	14.0	12.6	—	—	13.1

Values for output speed (rpm) are theoretical at 95% volumetric efficiency using nominal displacement values.

Values for output speed (mph) use the calculated speed (rpm) values and assume a rolling radius of 0.5 inches less than one-half of the tire diameter.

Vehicle Ratings

For use with tires up to 26" diameter and gross vehicle weights (GVW) up to 2500 lb. See side load chart on page 27 for specific side load ratings.

Brake holding torque capacity = 4000 lb-in per side
Transmission weight = 66 lb

Radial Load

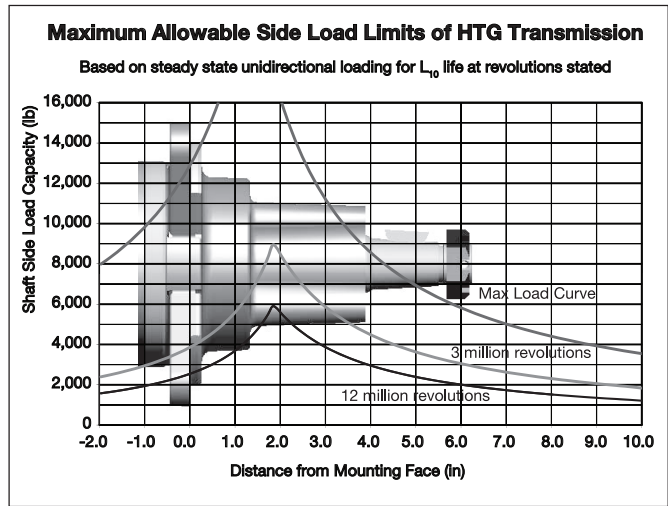
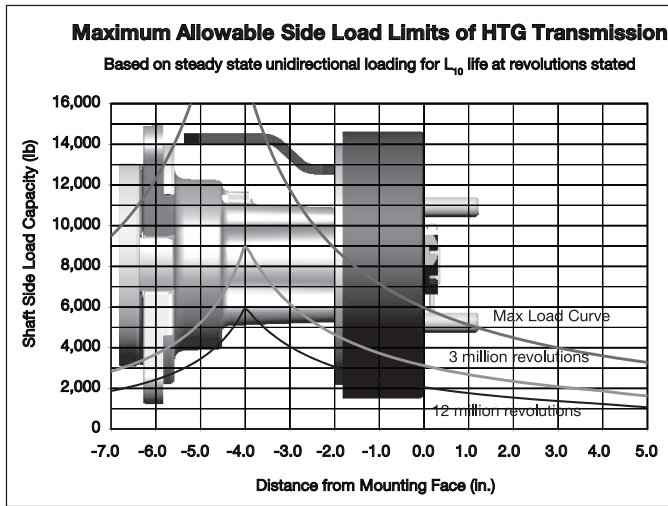

With Brake

Without Brake

The dynamic side load curves are based on uni-directional steady state loads for L_{10} bearing life at stated number of revolutions. The maximum load curve is defined by bearing static load capacity. This curve should not be exceeded at any time including shock loads.

Equation to Calculate the Expected Radial Bearing Life

Equation to calculate the dynamic bearing life for a given load:

Use F_a , F_b and S in equation to determine hours of L_{10} bearing life.

$$L = \frac{3 \times 10^6}{60 \times S} \left\{ \frac{F_a}{F_b} \right\}^{3.33}$$

Where:

S = Shaft Speed RPM

L = Life In Hours

F_a = Dynamic side load defined by the 3 million revolutions curve at a distance from mounting flange.

F_b = Application side load.

Note: Calculations are based on L_{10} bearing life per ISO 281.

5-Bolt Hub

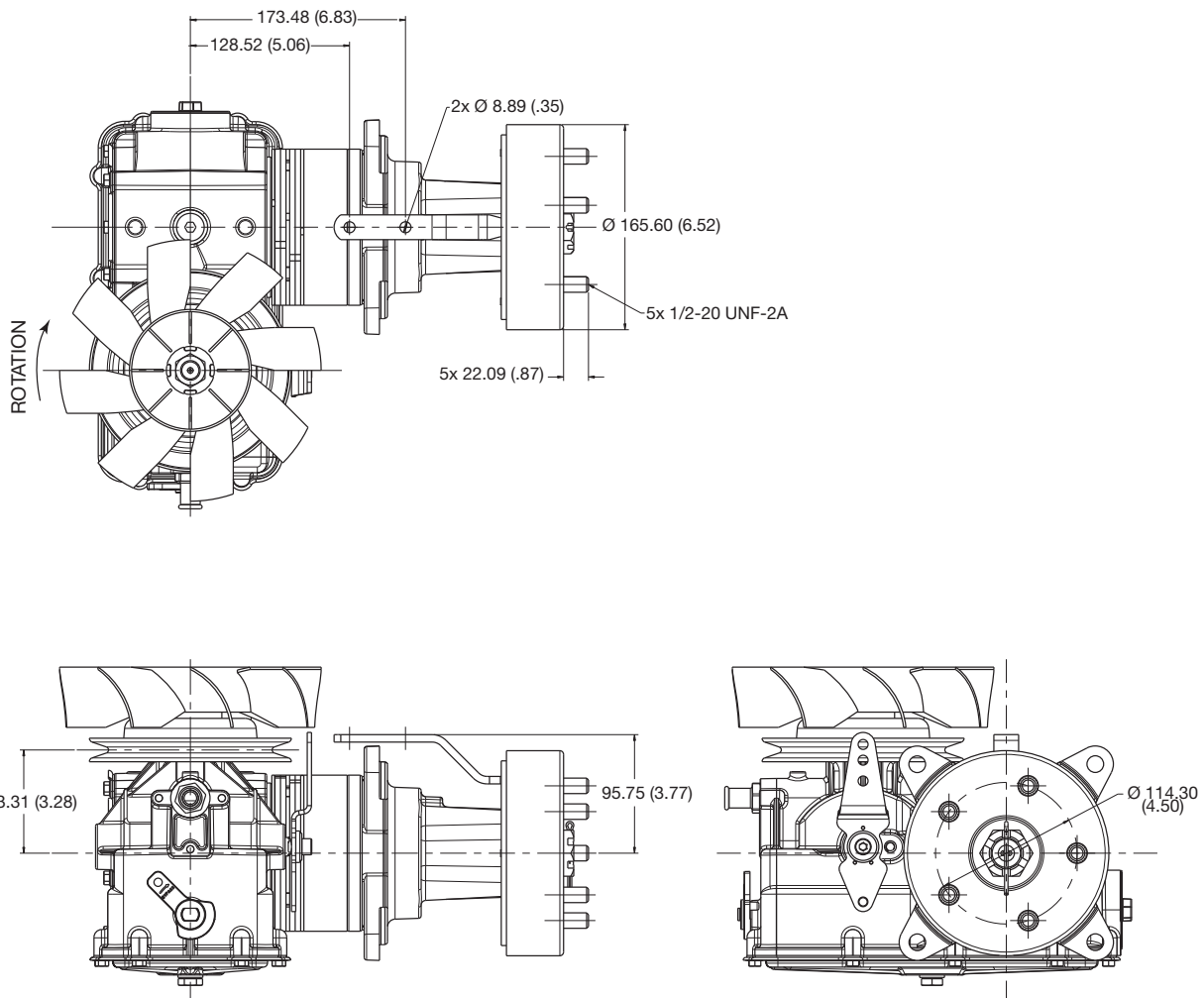

- HTG shown with:
 - 5-bolt hub
 - 6" pulley
 - Two-hole brake lever
 - Control arm / no return-to-neutral mechanism

English equivalents for metric specifications are shown in ().

4-Bolt Hub

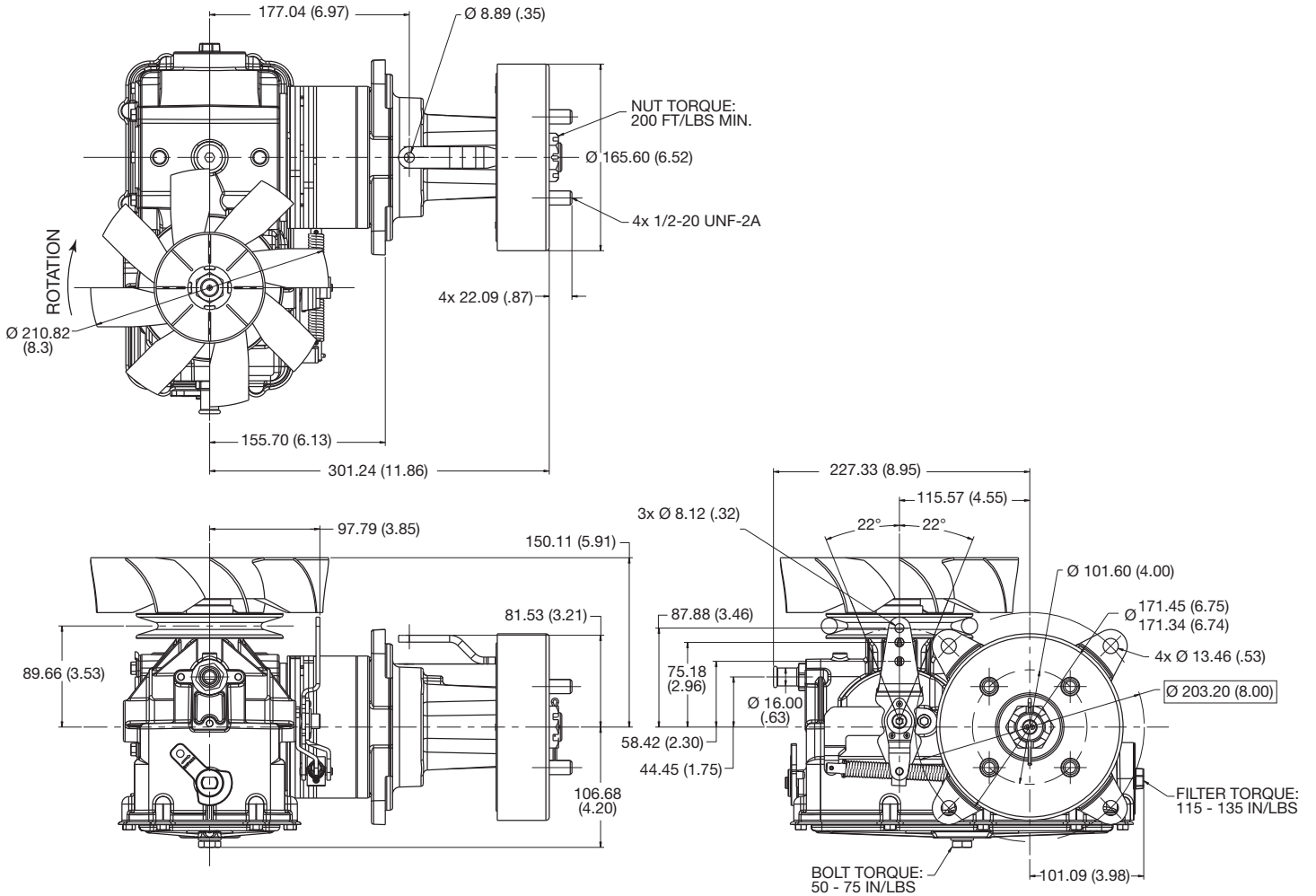

- HTG shown with:
 - 4-bolt hub
 - 5" pulley
 - Single-hole brake lever "sized to fit through pilot diameter"
 - Return-to-neutral mechanism

English equivalents for metric specifications are shown in ().

Fluid

Each unit is pre-filled from the factory. Top off expansion tanks (HTG only) with a premium grade hydraulic or engine oil. Fluids with a minimum of .125% zinc (or equivalent) anti-wear package should be used. A mineral or synthetic based 10W40 engine oil or hydraulic fluid is recommended.

Recommended fluids are:

- Castrol Syntec 5w-50
- Amsoil AW ISO 68
- Shell TTF-SB

Hydraulic Fluid and Filter Service Intervals**HTE Transmissions:**

The HTE transmission is intended to be sealed throughout the warranty life of 750 hours.

HTJ Transmissions:

The hydraulic oil and filter should be changed at 200 - 300 hours of use. If one of the recommended fluids above are used, change the oil and filter at 500 hour intervals thereafter. If other fluids are used, change the oil and filter at 250 hour intervals thereafter.

HTG Transmissions:

The hydraulic oil and filter should be changed at 200 - 300 hours of use. If one of the recommended fluids above are used, change the oil and filter at 500 hour intervals thereafter. If other fluids are used, change the oil and filter at 250 hour intervals thereafter.

Shock Valves

Shock valves limit the circuit pressure to prevent internal damage from pressure spikes. These are not “full-flow” relief valves. Continuous operation at the shock valve pressures will cause overheating and internal damage.

Control Orifices

Shock valve orifices affect transmission responsiveness. Larger orifices allow for smoother operation, while smaller orifices offer greater responsiveness for the skilled operator.

Wheel Lug Nut Torque

Recommended torque for the lug nuts mounting the wheel to the brake drum is 65 – 75 ft lb

**CAUTION! Static Brake Only**

The parking brakes are designed for static use only, i.e., the brake should not be used to stop the vehicle and the vehicle should not be started while the brake is applied. Using the brake in a dynamic condition (while the vehicle is moving) will damage and reduce the holding capacity of the brake. If the brake does not hold because it has been damaged, personal injury or property damage could result.

Brake Holding Capacity and Periodic Test

The brake holding capacity rating is based on actual holding capacity when new. If properly used as a static brake only, the holding capacity will slowly decrease with time. Since holding capacity will slowly decrease over time, a proper maintenance procedure should include periodically testing the holding capacity of the brake. This can be achieved by running a vehicle ramp test per OEM instructions.

The items described in this document and other documents and descriptions provided by Parker Hannifin Corporation, Hydraulics Group, and its authorized distributors ("Seller") are hereby offered for sale at prices to be established by Seller. This offer and its acceptance by any customer ("Buyer") shall be governed by all of the following Terms and Conditions. Buyer's order for any item described in its document, when communicated to Seller verbally, or in writing, shall constitute acceptance of this offer. All goods or work described will be referred to as "Products".

1. Terms and Conditions. Seller's willingness to offer Products, or accept an order for Products, to or from Buyer is expressly conditioned on Buyer's assent to these Terms and Conditions and to the terms and conditions found on-line at www.parker.com/saleterms/. Seller objects to any contrary or additional term or condition of Buyer's order or any other document issued by Buyer.

2. Price Adjustments; Payments. Prices stated on the reverse side or preceding pages of this document are valid for 30 days. After 30 days, Seller may change prices to reflect any increase in its costs resulting from state, federal or local legislation, price increases from its suppliers, or any change in the rate, charge, or classification of any carrier. The prices stated on the reverse or preceding pages of this document do not include any sales, use, or other taxes unless so stated specifically. Unless otherwise specified by Seller, all prices are F.O.B. Seller's facility, and payment is due 30 days from the date of invoice. After 30 days, Buyer shall pay interest on any unpaid invoices at the rate of 1.5% per month or the maximum allowable rate under applicable law.

3. Delivery Dates; Title and Risk; Shipment. All delivery dates are approximate and Seller shall not be responsible for any damages resulting from any delay. Regardless of the manner of shipment, title to any products and risk of loss or damage shall pass to Buyer upon tender to the carrier at Seller's facility (i.e., when it's on the truck, it's yours). Unless otherwise stated, Seller may exercise its judgment in choosing the carrier and means of delivery. No deferral of shipment at Buyers' request beyond the respective dates indicated will be made except on terms that will indemnify, defend and hold Seller harmless against all loss and additional expense. Buyer shall be responsible for any additional shipping charges incurred by Seller due to Buyer's changes in shipping, product specifications or in accordance with Section 13, herein.

4. Warranty. Seller warrants that the Products sold hereunder shall be free from defects in material or workmanship for a period of eighteen (18) months from the date of delivery to Buyer or 2,000 hours of normal use, whichever occurs first. The prices charged for Seller's products are based upon the exclusive limited warranty stated above, and upon the following disclaimer: **DISCLAIMER OF WARRANTY: THIS WARRANTY COMPRISES THE SOLE AND ENTIRE WARRANTY PERTAINING TO PRODUCTS PROVIDED HEREUNDER. SELLER DISCLAIMS ALL OTHER WARRANTIES, EXPRESS AND IMPLIED, INCLUDING MERCHANTABILITY AND FITNESS FOR A PARTICULAR PURPOSE.**

5. Claims; Commencement of Actions. Buyer shall promptly inspect all Products upon delivery. No claims for shortages will be allowed unless reported to the Seller within 10 days of delivery. No other claims against Seller will be allowed unless asserted in writing within 60 days after delivery or, in the case of an alleged breach of warranty, within 30 days after the date within the warranty period on which the defect is or should have been discovered by Buyer. Any action based upon breach of this agreement or upon any other claim arising out of this sale (other than an action by Seller for any amount due to Seller from Buyer) must be commenced within thirteen months from the date of tender of delivery by Seller or, for a cause of action based upon an alleged breach of warranty, within thirteen months from the date within the warranty period on which the defect is or should have been discovered by Buyer.

6. LIMITATION OF LIABILITY. UPON NOTIFICATION, SELLER WILL, AT ITS OPTION, REPAIR OR REPLACE A DEFECTIVE PRODUCT, OR REFUND THE PURCHASE PRICE. IN NO EVENT SHALL SELLER BE LIABLE TO BUYER FOR ANY SPECIAL, INDIRECT, INCIDENTAL OR CONSEQUENTIAL DAMAGES ARISING OUT OF, OR AS THE RESULT OF, THE SALE, DELIVERY, NON-DELIVERY, SERVICING, USE OR LOSS OF USE OF THE PRODUCTS OR ANY PART THEREOF, OR FOR ANY CHARGES OR EXPENSES OF ANY NATURE INCURRED WITHOUT SELLER'S WRITTEN CONSENT, EVEN IF SELLER HAS BEEN NEGLIGENT, WHETHER IN CONTRACT, TORT OR OTHER LEGAL THEORY. IN NO EVENT SHALL SELLER'S LIABILITY UNDER ANY CLAIM MADE BY BUYER EXCEED THE PURCHASE PRICE OF THE PRODUCTS.

7. Contingencies. Seller shall not be liable for any default or delay in performance if caused by circumstances beyond the reasonable control of Seller.

8. User Responsibility. The user, through its own analysis and testing, is solely responsible for making the final selection of the system and Product and assuring that all performance, endurance, maintenance, safety and warning requirements of the application are met. The user must analyze all aspects of the application and follow applicable industry standards and Product information. If Seller provides Product or system options, the user is responsible for determining that such data and specifications are suitable and sufficient for all applications and reasonably foreseeable uses of the Products or systems.

9. Loss to Buyer's Property. Any designs, tools, patterns, materials, drawings, confidential information or equipment furnished by Buyer or any other items which become Buyer's property, may be considered obsolete and may be destroyed by Seller after two consecutive years have elapsed without Buyer placing an order for the items which are manufactured using such property. Seller shall not be responsible for any loss or damage to such property while it is in Seller's possession or control.

10. Special Tooling. A tooling charge may be imposed for any special tooling, including without limitation, dies, fixtures, molds and patterns, acquired to manufacture Products. Such special tooling shall be and remain Seller's property notwithstanding payment of any charges by Buyer. In no event will Buyer acquire any interest in apparatus belonging to Seller which is utilized in the manufacture of the Products, even if such apparatus has been specially converted or adapted for such manufacture and notwithstanding any charges paid by Buyer. Unless otherwise agreed, Seller shall have the right to alter, discard or otherwise dispose of any special tooling or other property in its sole discretion at any time.

11. Buyer's Obligation; Rights of Seller. To secure payment of all sums due or otherwise, Seller shall retain a security interest in the goods delivered and this agreement shall be deemed a Security Agreement under the Uniform Commercial Code. Buyer authorizes Seller as its attorney to execute and file on Buyer's behalf all documents Seller deems necessary to perfect its security interest. Seller shall have a security interest in, and lien upon, any property of Buyer in Seller's possession as security for the payment of any amounts owed to Seller by Buyer.

12. Improper use and Indemnity. Buyer shall indemnify, defend, and hold Seller harmless from any claim, liability, damages, lawsuits, and costs (including attorney fees), whether for personal injury, property damage, patent, trademark or copyright infringement or any other claim, brought by or incurred by Buyer, Buyer's employees, or any other person, arising out of: (a) improper selection, improper application or other misuse of Products purchased by Buyer from Seller; (b) any act or omission, negligent or otherwise, of Buyer; (c) Seller's use of patterns, plans, drawings, or specifications furnished by Buyer to manufacture Product; or (d) Buyer's failure to comply with these terms and conditions. Seller shall not indemnify Buyer under any circumstance except as otherwise provided.

13. Cancellations and Changes. Orders shall not be subject to cancellation or change by Buyer for any reason, except with Seller's written consent and upon terms that will indemnify, defend and hold Seller harmless against all direct, incidental and consequential loss or damage. Seller may change product features, specifications, designs and availability with notice to Buyer.

14. Limitation on Assignment. Buyer may not assign its rights or obligations under this agreement without the prior written consent of Seller.

15. Entire Agreement. This agreement contains the entire agreement between the Buyer and Seller and constitutes the final, complete and exclusive expression of the terms of the agreement. All prior or contemporaneous written or oral agreements or negotiations with respect to the subject matter are herein merged.

16. Waiver and Severability. Failure to enforce any provision of this agreement will not waive that provision nor will any such failure prejudice Seller's right to enforce that provision in the future. Invalidation of any provision of this agreement by legislation or other rule of law shall not invalidate any other provision herein. The remaining provisions of this agreement will remain in full force and effect.

17. Termination. This agreement may be terminated by Seller for any reason and at any time by giving Buyer thirty (30) days written notice of termination. In addition, Seller may by written notice immediately terminate this agreement for the following: (a) Buyer commits a breach of any provision of this agreement (b) the appointment of a trustee, receiver or custodian for all or any part of Buyer's property (c) the filing of a petition for relief in bankruptcy of the other Party on its own behalf, or by a third party (d) an assignment for the benefit of creditors, or (e) the dissolution or liquidation of the Buyer.

18. Governing Law. This agreement and the sale and delivery of all Products hereunder shall be deemed to have taken place in and shall be governed and construed in accordance with the laws of the State of Ohio, as applicable to contracts executed and wholly performed therein and without regard to conflicts of laws principles. Buyer irrevocably agrees and consents to the exclusive jurisdiction and venue of the courts of Cuyahoga County, Ohio with respect to any dispute, controversy or claim arising out of or relating to this agreement. Disputes between the parties shall not be settled by arbitration unless, after a dispute has arisen, both parties expressly agree in writing to arbitrate the dispute.

19. Indemnity for Infringement of Intellectual Property Rights. Seller shall have no liability for infringement of any patents, trademarks, copyrights, trade dress, trade secrets or similar rights except as provided in this Section. Seller will defend and indemnify Buyer against allegations of infringement of U.S. patents, U.S. trademarks, copyrights, trade dress and trade secrets ("Intellectual Property Rights"). Seller will defend at its expense and will pay the cost of any settlement or damages awarded in an action brought against Buyer based on an allegation that a Product sold pursuant to this Agreement infringes the Intellectual Property Rights of a third party. Seller's obligation to defend and indemnify Buyer is contingent on Buyer notifying Seller within ten (10) days after Buyer becomes aware of such allegations of infringement, and Seller having sole control over the defense of any allegations or actions including all negotiations for settlement or compromise. If a Product is subject to a claim that it infringes the Intellectual Property Rights of a third party, Seller may, at its sole expense and option, procure for Buyer the right to continue using the Product, replace or modify the Product so as to make it noninfringing, or offer to accept return of the Product and return the purchase price less a reasonable allowance for depreciation. Notwithstanding the foregoing, Seller shall have no liability for claims of infringement based on information provided by Buyer, or directed to Products delivered hereunder for which the designs are specified in whole or part by Buyer, or infringements resulting from the modification, combination or use in a system of any Product sold hereunder. The foregoing provisions of this Section shall constitute Seller's sole and exclusive liability and Buyer's sole and exclusive remedy for infringement of Intellectual Property Rights.

20. Taxes. Unless otherwise indicated, all prices and charges are exclusive of excise, sales, use, property, occupational or like taxes which may be imposed by any taxing authority upon the manufacture, sale or delivery of Products.

21. Equal Opportunity Clause. For the performance of government contracts and where dollar value of the Products exceed \$10,000, the equal employment opportunity clauses in Executive Order 11246, VEVRAA, and 41 C.F.R. §§ 60-1.4(a), 60-741.5(a), and 60-250.4, are hereby incorporated.

Parker Hydraulics International Sales Offices

North America

Hydraulics Group Headquarters

6035 Parkland Boulevard
Cleveland, OH 44124-4141 USA
Tel: 216-896-3000
Fax: 216-896-4031

Parker Hannifin Canada Division

160 Chisholm Drive Milton
Ontario, Canada L9T 3G9
Tel: 905-693-3000
Fax: 905-876-1958

Mexico

Parker Hannifin de México

Industrial Hydraulic Sales
Eje Uno Norte No. 100
Parque Industrial Toluca 2000
Toluca, Edo. de Mexico CP 50100
Tel: 52 72 2275 4200
Fax: 52 72 2279 9308

Parker Hannifin de México

Mobile Hydraulic Sales
Via de FFCC a Matamoros 730
Apodaca, NL CP de Mexico 66600
Tel: 52 81 8156 6000
Fax: 52 81 8156 6068

Europe

Hydraulics Group Headquarters

La Tuilière 6
1163 Etoy - Switzerland
Tel: 41 21 821 8500
Fax: 41 21 821 8580

South Africa

Parker Hannifin Africa Pty Ltd

P.O. Box 1153
ZA-Kempton Park 1620,
Republic of South Africa
Tel: 27 11 961 0700
Fax: 27 11 392 7213

Mobile Sales

Mobile Sales Organization and Global Sales

850 Arthur Avenue
Elk Grove Village, IL 60007 USA
Tel: 847-258-6200
Fax: 847-258-6299

Industrial Sales

Central Region

1042 Maple Avenue
Unit 331
Lisle, IL 60532 USA
Tel: 630-964-0796

Great Lakes Region

6035 Parkland Boulevard
Cleveland, OH 44124-4141 USA
Tel: 216-896-2740
Fax: 866-498-7507

Gulf Region

20002 Standing Cypress Drive
Spring, TX 77379 USA
Tel: 817-473-4431
Fax: 888-227-9454

Southwest Region

700 S. 4th Avenue
Mansfield, TX 76063 USA
Tel: 817-473-4431
Fax: 888-227-9454

Mid Atlantic & Southeast Regions

1225 Old Alpharetta Rd
Suite 290
Alpharetta, GA 30005 USA
Tel: 770-619-9767
Fax: 770-619-9806

Midwest Region

8145 Lewis Road
Minneapolis, MN 55427 USA
Tel: 763-513-3535
Fax: 763-544-3418

Northeast Region

P.O. Box 396
Pine Brook, NJ 07058 USA
Tel: 973-227-2565
Fax: 973-227-2467

Northwest Region

6458 North Basin Avenue
Portland, OR 97217 USA
Tel: 503-283-1020
Fax: 866-611-7308

Pacific Region

8460 Kass Drive
Buena Park, CA 90621 USA
Tel: 714-228-2509
Fax: 714-228-2511

Asia Pacific

Parker Hannifin Shanghai Ltd.

280 Yunqiao Road,
Jin Qiao Export Processing Zone
Shanghai 201206, China
Tel: 86 21 2899 5000
Fax: 86 21 6445 9717

Parker Hannifin Hong Kong Ltd.

8/F, Kin Yip Plaza
9 Cheung Yee Street
Cheung Sha Wan, Hong Kong
Tel: 852 2428 8008
Fax: 852 2480 4256

Parker Hannifin Korea Ltd.

9F KAMCO Yangjae Tower
949-3 Dogok1-dong, Gangnam-gu
Seoul, 135-860, Korea
Tel: 82 2 559 0400
Fax: 82 2 556 8187

Parker Hannifin India Pvt Ltd.

Plot No. EL-26, MIDC,
TTC Industrial Area
Mahape, Navi Mumbai, 400 709, India
Tel: 91 22 6513 7081
Fax: 91 22 2768 6841

Parker Hannifin Australia

Parker Hannifin Pty Ltd.
9 Carrington Road
Castle Hill, NSW 2154, Australia
Tel: 612 9634 7777
Fax: 612 9842 5111

Latin America

Parker Hannifin Ind. e Com. Ltda Hydraulics Division

Av. Frederico Ritter, 1100
94930-000 Cachoeirinha RS, Brazil
Tel: 55 51 3470 6090
Fax: 55 51 3470 9281

Parker Hannifin Argentina S.A.I.C.

Stephenson 2711
1667-Tortuguitas-Malvinas Argentinas
Pcia. de Buenos Aires, Argentina
Tel: 54 3327 44 4129
Fax: 54 3327 44 4199

Pan American Division

7400 NW 19th Street, Suite A
Miami, FL 33126 USA
Tel: 305-470-8800
Fax: 305-470-8808

HY13-1595/US 10/2012

Parker Hannifin Corporation
Hydraulic Pump Motor Division

2745 Snapps Ferry Road
Greeneville, TN 37745
phone 423 639 8151
fax 423 787 2418
www.parker.com

